

**PORTASTAMPI SERIE EUROPA
EUROPEAN SERIES MOULD BASES**

La nostra storia

La **Tecnostar Group Srl** nasce nel 2011 come fase finale di una profonda ristrutturazione organizzativa della precedente realtà aziendale. Il 2018 rappresenta un punto di svolta con la realizzazione e distribuzione, in esclusiva, di una linea di Portastampi Serie Europa.

Le nostre piastre saranno marcate Tecnostar e prodotte in sinergia con due importanti costruttori Europei coinvolti in maniera diretta nel progetto, Ca-Be Snc e Sebastian Fustel, S.L.

Our History

Tecnostar Group Srl was founded in 2011 following a significant reorganization of the previous establishment. 2018 will be a turning point for the company with the launch of a new line of European standard mould bases, that will be distributed and produced exclusively.

The plates will be marked with the Tecnostar brand and produced with the sinergy of two important European manufacturers such as CA-BE Snc and Sebastian Fustel S.L.

Vasto assortimento

Disponiamo di un importante assortimento di prodotti pubblicati sul nostro e-commerce www.tecnostargroup.it.

Il nostro obiettivo in termini di prodotti offerti è quello di essere dinamici, cercando di soddisfare il mercato, e questo ci porta ad ampliare regolarmente la nostra offerta, grazie al costante aggiornamento tecnico che perseguiamo.

Vast range of products

We have a vast range of products published on our e-commerce website www.tecnostargroup.it.

Our objective, in relation to the products we offer, is to be dynamic and ahead of the market and this leads to a regular increase in our products thanks to the constant technical updates that we carry out.



Portastampi Made in Italy

“Portastampi in Acciaio Made in Italy”

Dal 1970 **CA-BE**, grazie alla continua innovazione, all'esperienza, alla serietà e alla professionalità, è divenuta una realtà in grado di servire il mercato nazionale ed internazionale.



Mould bases Made in Italy

“Steel mould bases Made in Italy”

From 1970 **CA-BE**, due to continuous innovation, experience, reliability and professionalism, has become a company able to satisfy the need of the national and international markets.



Partner internazionali

“Qualità, lavoro e impegno verso i nostri clienti”

In oltre 50 anni di storia, da piccolo magazzino di acciai a grande industria internazionale per la realizzazione di piastre per stampi, la **SEBASTIAN FUSTEL S.L.** ha sempre superato nuove sfide.



International partners

“Quality, work and commitment to our costumers”

In over fifty years of history, from its origin as a small steel warehouse to an industrial manufacturer of mould plates with international presence, **SEBASTIAN FUSTEL S.L.** has always overcome new challenges.



Semplice e Veloce

All'interno del nostro sito web

www.tecnostargroup.it troverai una sezione dedicata per la creazione del tuo portastampo secondo gli standard europei.

Semplice ed intuitivo, permette di creare il tuo portastampo e il download nei più comuni formati 3D.

Easy and Fast

Inside our website **www.tecnostargroup.it**, there is a dedicated section for the modelling of your mould base according to the european standard. Easy and user friendly, you can create your mould base and download it in the most used 3D format.

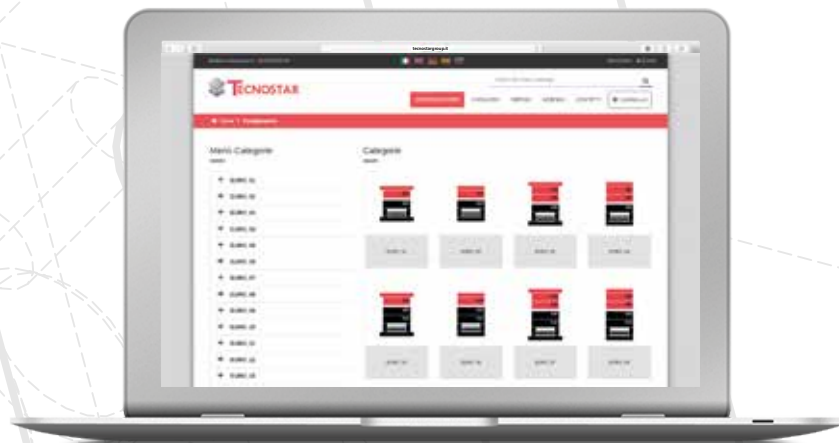

Tutto quello che ti serve

Potrai creare il tuo portastampo completo dei normalizzati standard per i nostri modelli. Consultando il sito **www.ranco.biz** potrai cercare le soluzioni alternative e personalizzate per le tue esigenze produttive.

Everything you need

You can create your own mould base with all the standard parts you need. Visiting our website **www.ranco.biz**, you can find your personal and alternative choice for your production.

by

RANCO



Come ordinare - How to order	6
Piastre lavorate - Machined plates	7
Tolleranze - Tolerances	8
Specifiche - Specifications	10
PIASTRE P - P PLATES	
Piastre non standard - Custom plates	14
Materiali standar - Standard materials	15
Piastre standard - Standard Plates	17
PIASTRE PORTASTAMPI - MOULD BASES PLATES	
Piastre non standard - Custom plates	22
Materiali standar - Standard materials	23
Serie standard - Standard series	25
156	25
196	27
246	31
296	35
346	40
396	46
446	52
496	57
ELEMENTI DI GUIDA - GUIDING ITEMS	
	63

Da catalogo - From catalogue

246x246

PF45

S	Material
27	1.1730

PD15

S	Material
27	1.1730

S50

S	Material
27	
30	

PD15-296x246x27-1730

Piastra - Plate

B

L

S

Materiale - Material

E-commerce

Registrati: registrati sul nostro sito web e scarica il nostro catalogo in formato PDF e i file 3D nei più diffusi formati CAD.

Richiedi l'offerta: invia la richiesta di quotazione. Richiedi l'abilitazione ai listini personalizzati al nostro ufficio commerciale.

Invia l'ordine: consulta i prezzi e le disponibilità in tempo reale. Mandi gli ordini direttamente dal nostro sito web e ricevi un rapido riscontro.

Sign up: sign up on our website and download the complete catalogue in PDF and the 3D files of our products in the most widely used CAD formats.

Requests for quotation: send a quotation request. Ask the Sales Department for your customized price list.

Place and order: check out the prices and stock availability in real time. Send the orders directly to our website and receive a quick answer.

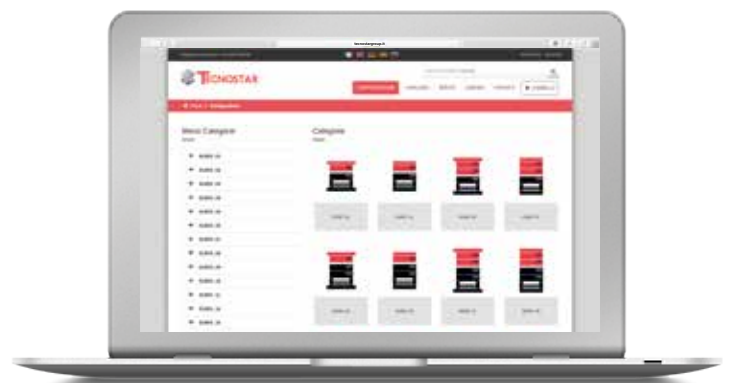

www.tecnostargroup.it

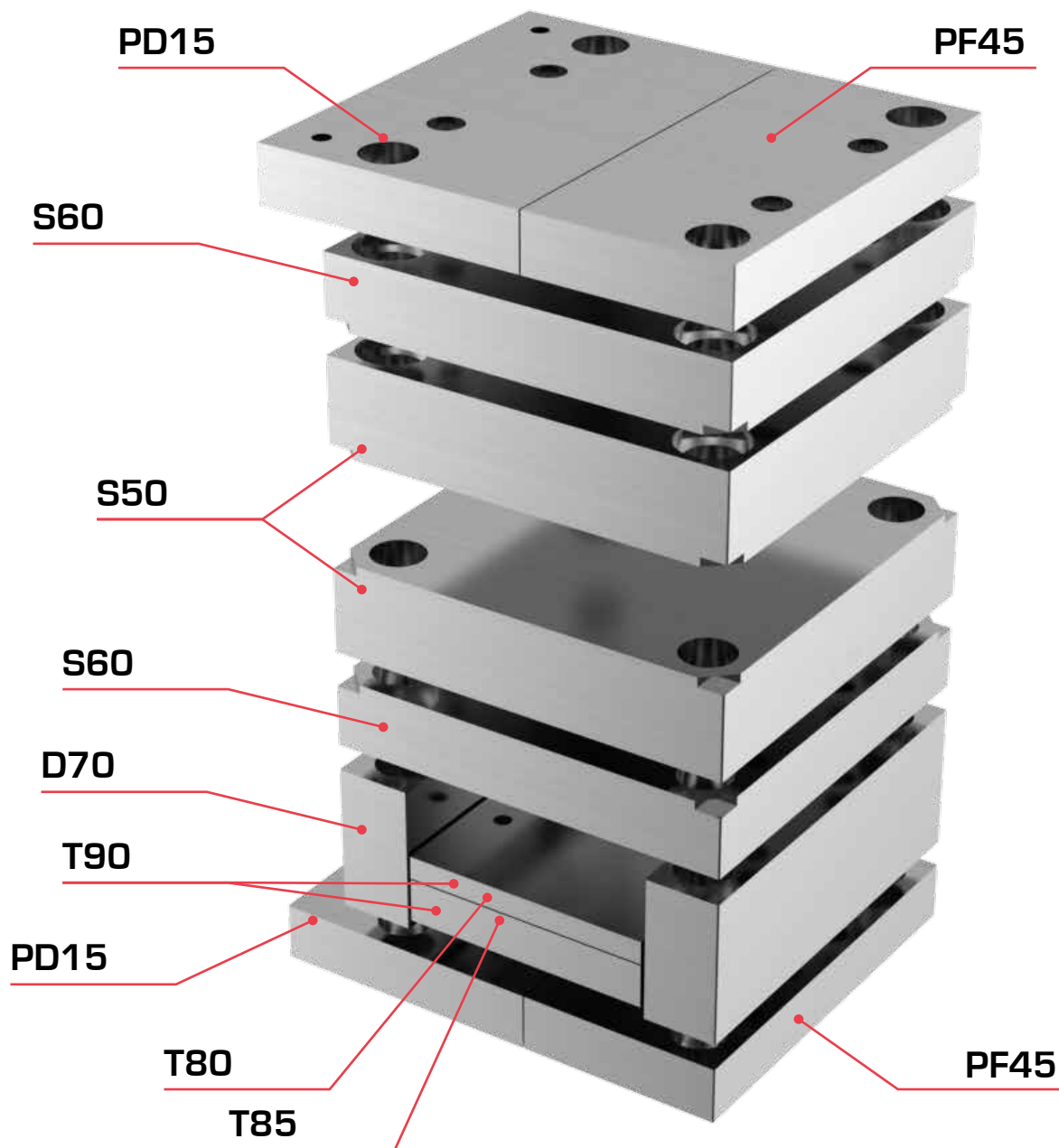

Piastra Plate	Descrizione Description
PD15	Piastra di chiusura debordante Clamp plate, width salient
PF45	Piastra di chiusura non debordante Flush clamp plate
S50	Piastra porta-impronta Cavity plate
S60	Contropiastra Backing plate
D70	Distanziale Riser
T80	Piastra porta Estrazione Ejector retaining plate
T85	Piastra spingi Estrazione Ejector base plate
T90	Tavolino estrazione completo di Normalizzati Ejector set with standard items

S50-S60

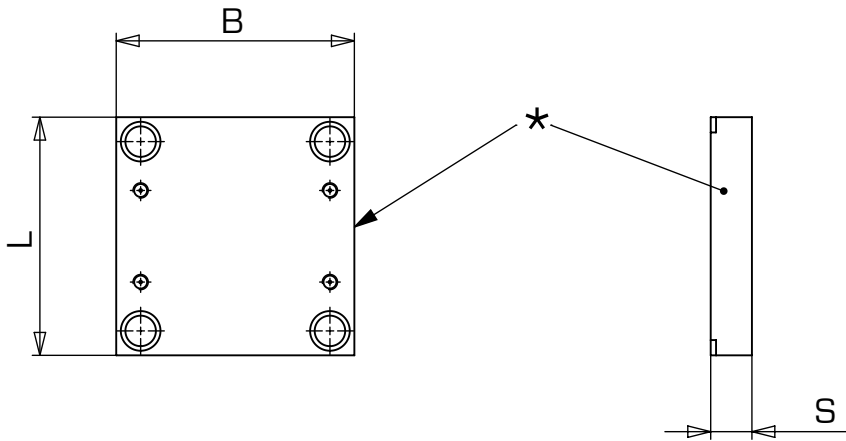

Rettificato Grinded	B/L	± 0.015
------------------------	-----	---------

Fresato* Milled*	B/L	+ 0
		+ 0.05

Rettificato Grinded	S	+ 0.3
		+ 0.1

PD15

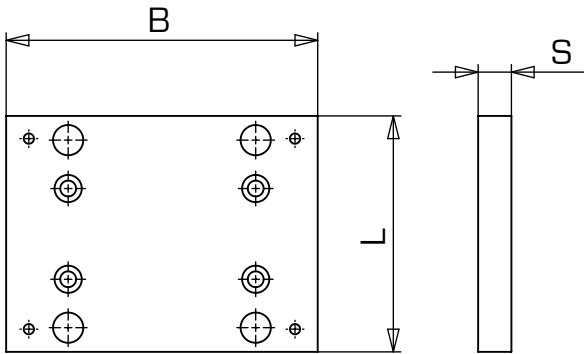

T80-T85/T90

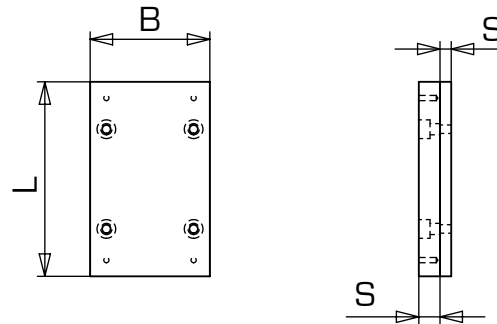

PF45

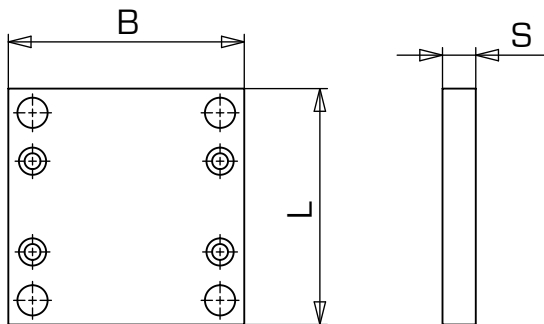

B/L	+ 0.1
	0

S	+ 0.05
	0

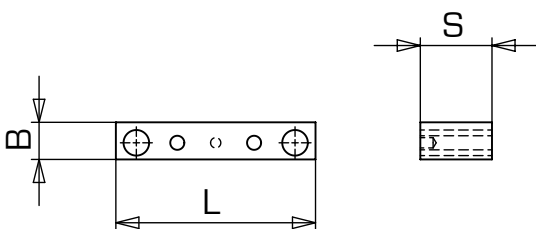

D70





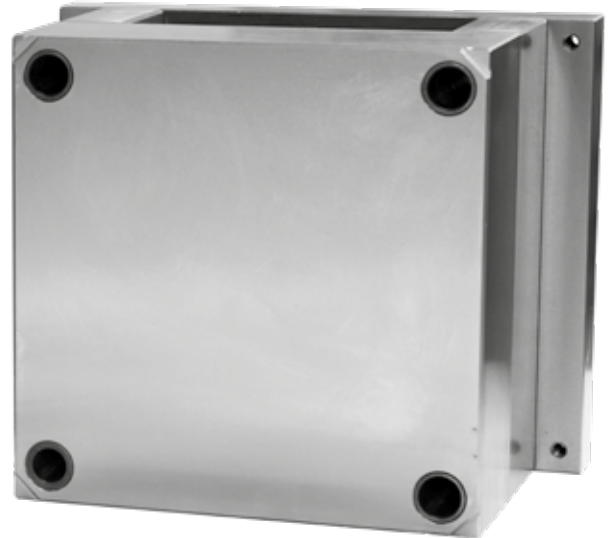

































B/L	+ 0.3
	0

S	+ 0.05
	0



-  S50 e S60 hanno i lati esterni rettificati
 S50 and S60 are grinded on the external sides
-  S50 e S60 hanno i lati esterni fresati, con riferimento a zero sui 4 lati B e L
 S50 and S60 are milled on the external sides, with reference to zero on all four sides B and L
-  S50 e S60 hanno il lato esterno fresato, con riferimento a zero solo su un lato L
 S50 and S60 are milled on the external side, with reference to zero on only one side L

L	B							
	156	196	246	296	346	396	446	496
156								
196								
246								
296								
346								
396								
446								
496								
546								
596								
696								

Forature - Holes

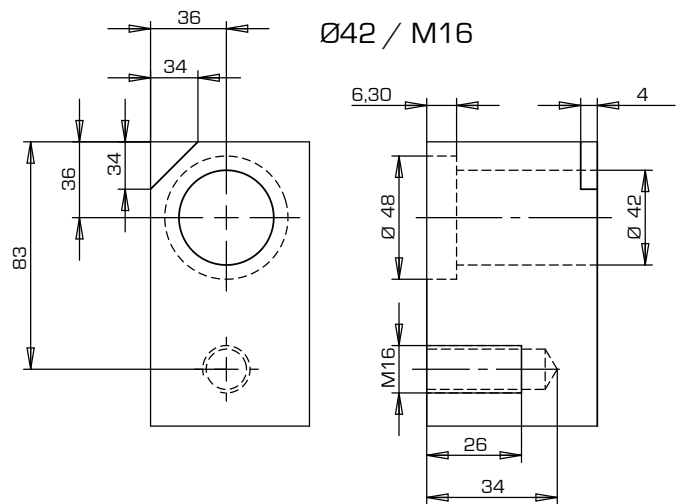
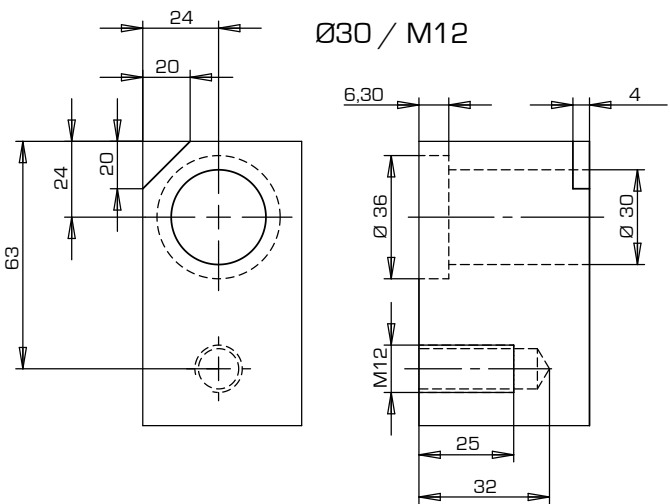
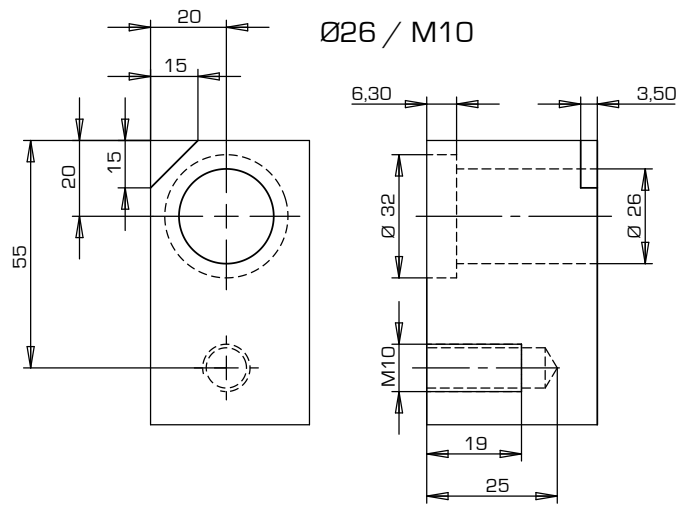
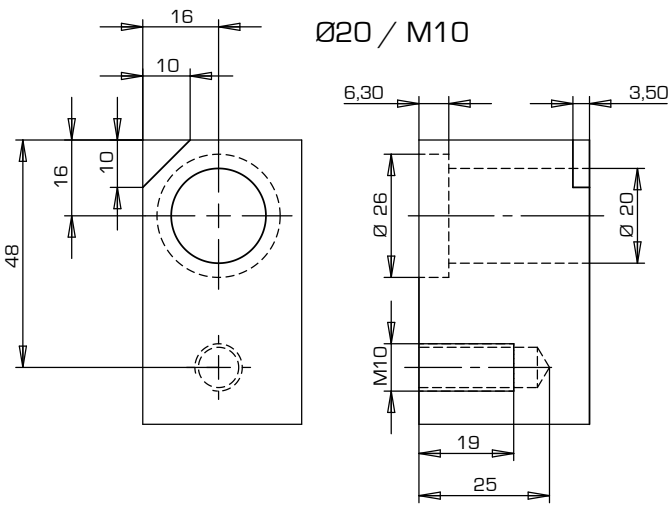

Le piastre S50 con altezza 27-36 vengono fornite con i fori di fissaggio passanti

The S50 plates with a height of 27-36 are supplied with through fixing holes

Fissaggi - Fixings

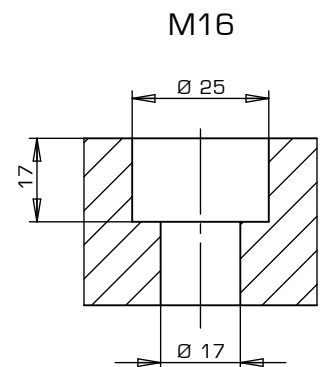
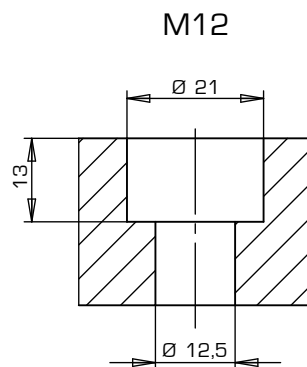
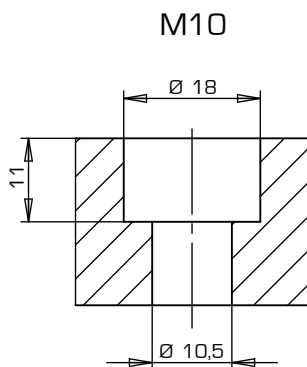

Lavorazione Filetti - Thread Machining

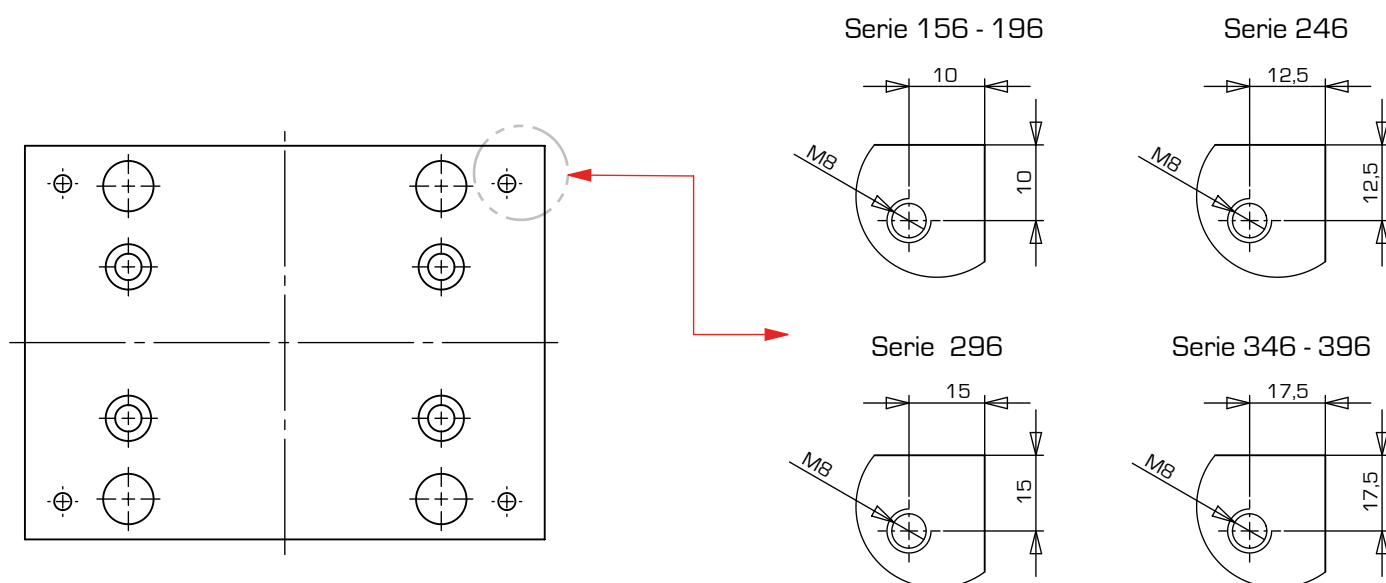

I filetti sono presenti sulle piastre PD15 fino alla serie 396

The threads are available from the PD15 plates up to 396 series.

Lavorazioni speciali - Custom machining

Tecnostar, oltre ad offrire un'ampia scelta di piastre standard pronte in stock, propone lavorazioni speciali quali:

1. smussi personalizzati
2. filetti per il fissaggio dei golfari
3. foratura profonda
4. incolonnamento non a catalogo
5. lavorazioni di piastre a disegno del cliente

Per questo tipo di servizio è necessario il disegno formato CAD 2D/3D, con cui verrà formulato un preventivo con tempi di consegna e costi.

Tecnostar offers a wide selection of standard plates ready in stock and also provide custom processing such as:

1. custom chamfers
2. special threads for eyebolts
3. deeper than standard hole drillings
4. custom guiding position
5. custom plate machining according to drawing

For this kind of service relevant 2D / 3D CAD drawings are required in order to make the proper quotation with expected lead time and prices.

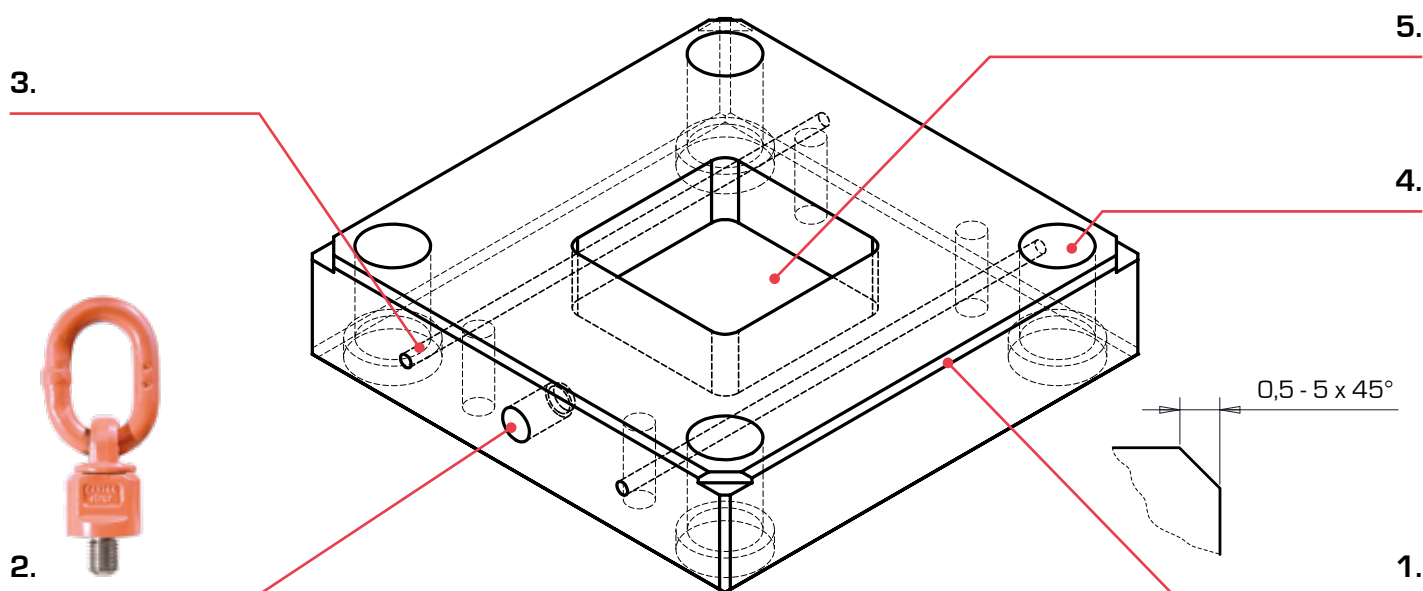

PIASTRE P
P PLATES

Materiali non a catalogo - Custom materials

Tecnostar, a richiesta, offre un'ampia scelta di materiali alternativi per le Piastre P:

Tecnostar offers a wide selection of alternative materials for the P Plates upon request:

Materiali Disponibili Available Materials							
1.1730	1.2083	1.2085	1.2343	1.2344	1.2379	1.2714	1.2738
●	●	●	●	●	●	●	●

Dimensioni non a catalogo - Custom dimensions

La nostra offerta di personalizzazioni non si ferma alla sola scelta dei materiali.

Our range of customized features involves not only the materials.

Possiamo fornire piastre di dimensioni non presenti a catalogo secondo le richieste del cliente.

We can also provide custom dimension plates according to customers' needs.

Come lavorazioni sui lati B e L possiamo offrire solo il taglio o la fresatura.

The processing on sides B and L can be provided with a simple cut or milled.

Mentre lo spessore S può essere fresato o rettificato.

The plate thickness S can be milled or grinded.

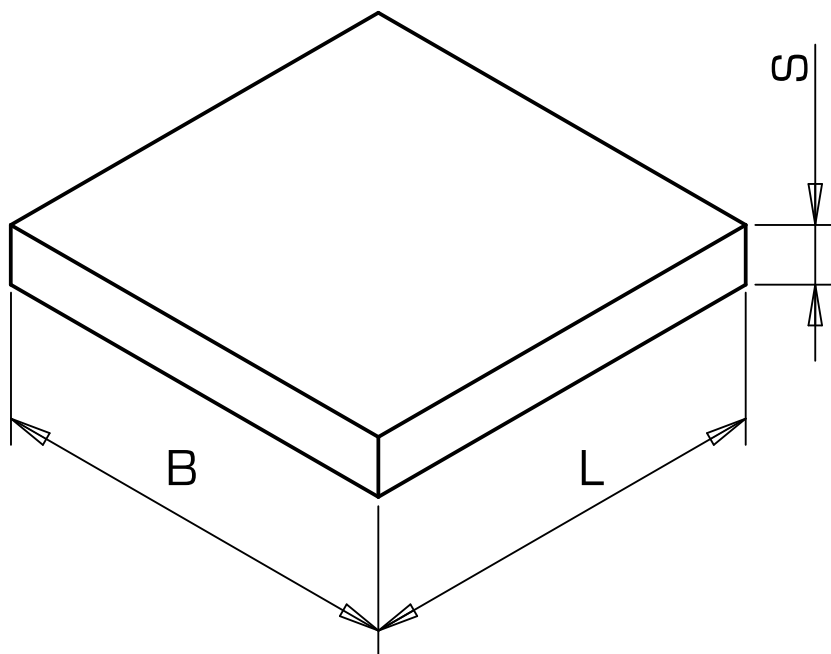

Acciaio 1.2311 - Steel 1.2311

Composizione chimica Chemical composition	C: 0,45/0,50 % Mn: 1,50 % Cr: 1,90 % Mo: 0,20 %				
Proprietà dell'Acciaio Steel properties	Buona lavorabilità, migliore lucidatura rispetto a 1.2312 Good machining, better polishing than 1.2312				
Applicazioni Applications	Acciaio per stampaggio ad iniezione. Steel for injection moulds.				
Stato alla consegna Supply condition	Trattamento di addolcimento e rinvenimento, 950-1100 N/mm ² Quenched and tempered, 950-1100 N/mm ²				
Espansione Termica Thermal expansion	$\left(\frac{10^{-6} \cdot m}{m \cdot k} \right)$	$\frac{20-100^{\circ}C}{12,1}$	$\frac{20-200^{\circ}C}{12,7}$	$\frac{20-300^{\circ}C}{13,2}$	$\frac{20-400^{\circ}C}{13,6}$
Conduttività termica Thermal conductivity	$\left(\frac{W}{m \cdot k} \right)$	$\frac{20^{\circ}C}{39,6}$	$\frac{300^{\circ}C}{39,2}$		
Ricottura di lavorabilità Soft annealing	Temperatura: 710-740 °C Raffreddamento: in forno Durezza: max. 235 HB Temperature: 710-740 °C Cooling: oven Hardness: max. 235 HB				
Ricottura di distensione Stress relief annealing	Temperatura: 500-550 °C Raffreddamento: in forno Temperature: 500-550 °C Cooling: oven				
Temperatura Hardening	Temperatura: 800-850 °C Raffreddamento: olio a bagno caldo 180-220 °C Temperature: 800-850 °C Cooling: oil, hot bath 180-220 °C				

Diagramma di ciclo termico
Thermal cycle diagram



Diagramma di trasformazione durante raffreddamento continuo
Continuous cooling transformation diagram



Diagramma di rinvenimento
Tempering diagram

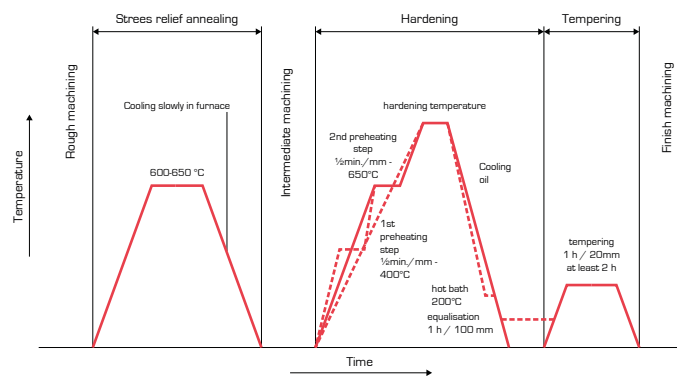

Acciaio 1.2312 - Steel 1.2312

Composizione chimica Chemical composition	C: 0,45/0,50 % Mn: 1,40/1,60 % Si: 0,30/0,50 % Cr: 1,80/2,00% Mo: 0,15/0,25 % S: 0,05/0,10 %				
Proprietà dell'Acciaio Steel properties	Acciaio per stampaggio plastico con solfuro. Lucidabile, migliore lavorabilità rispetto a 1.2311. Plastic mould steel with additional sulphur. Polishable, better machinability than 1.2311.				
Applicazioni Applications	Costruzione di stampi e portastampi per il settore plastico, stampaggio a iniezione e pressofusione. Mould plates for plastic moulds, injection moulding and dies.				
Stato alla consegna Supply condition	Trattamento di addolcimento e rinvenimento, 950-1100 N/mm ² Quenched and tempered, 950-1100 N/mm ²				
Espansione Termica Thermal expansion	$\left(\frac{10^{-6} \cdot m}{m \cdot k} \right)$	$\frac{20-100^{\circ}C}{12,3}$	$\frac{20-200^{\circ}C}{12,9}$	$\frac{20-300^{\circ}C}{13,3}$	$\frac{20-400^{\circ}C}{13,5}$
Conduktività termica Thermal conductivity	$\left(\frac{W}{m \cdot k} \right)$	$\frac{20^{\circ}C}{39,6}$	$\frac{300^{\circ}C}{39,3}$		
Ricottura di lavorabilità Soft annealing	Temperatura: 710-740 °C Raffreddamento: in forno Durezza: max. 35 HB Temperature: 710-740 °C Cooling: oven Hardness: max. 35 HB				
Ricottura di distensione Stress relief annealing	Temperatura: 500-550 °C Raffreddamento: in forno Temperature: 500-550 °C Cooling: oven				
Tempratura Hardening	Temperatura: 830-870 °C Raffreddamento: olio a bagno caldo 180-220 °C Temperature: 830-870 °C Cooling: oil, hot bath 180-220 °C				

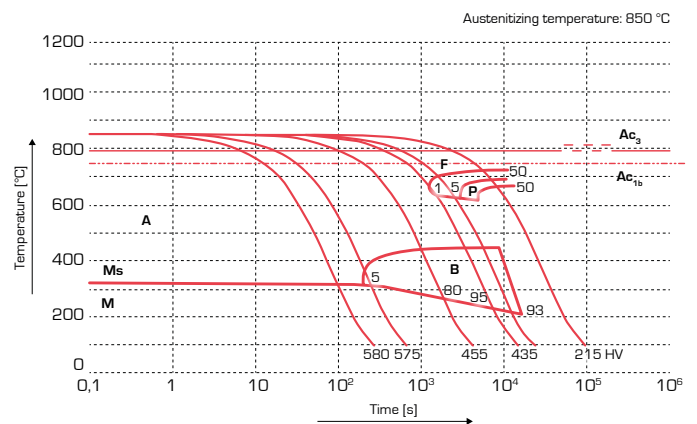
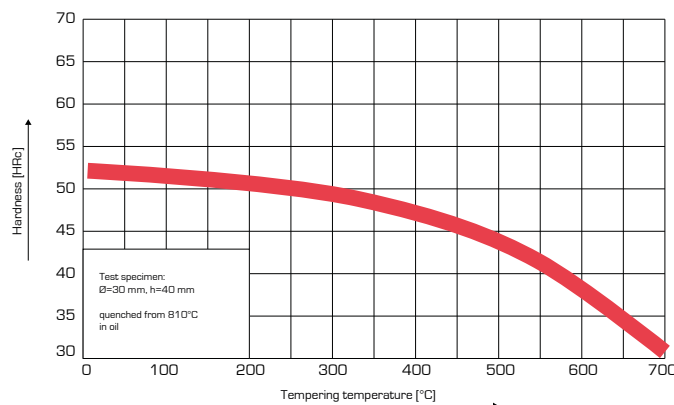
Diagramma di ciclo termico
Thermal cycle diagram



Diagramma di trasformazione durante raffreddamento continuo
Continuous cooling transformation diagram



Diagramma di rinvenimento
Tempering diagram

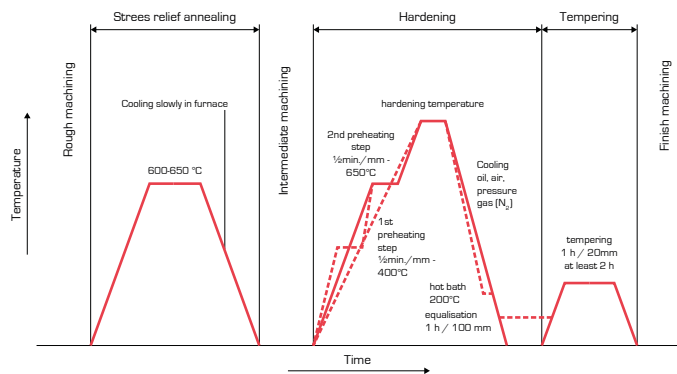

Piastre P - P Plates

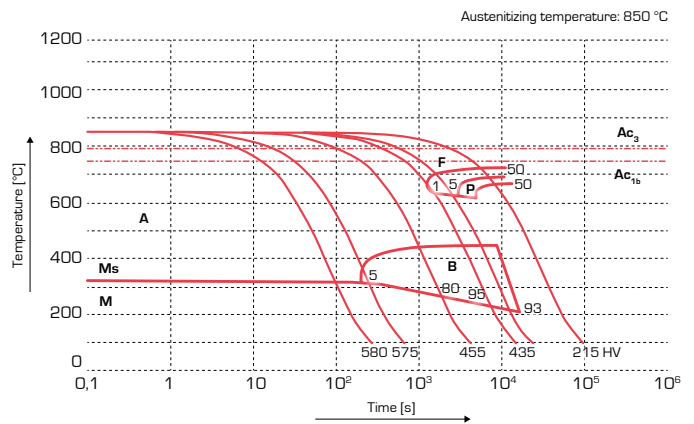
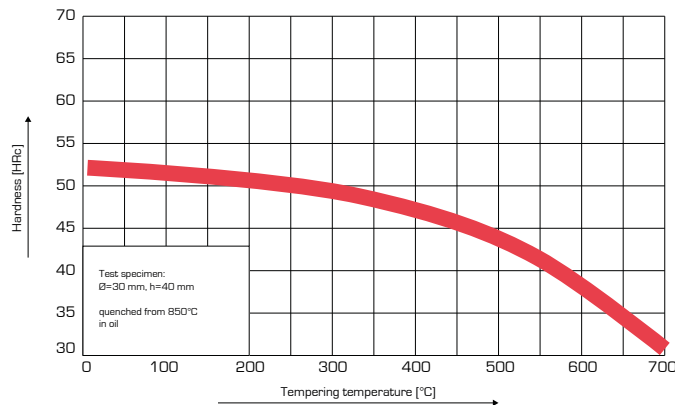
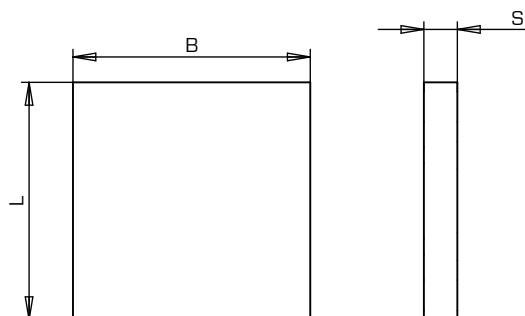

Fresato Milled	B/L	+ 0.2
		+ 0.3

Rettificato Grinded	S	+ 0.2
		+ 0.3

B	L	S	Material		B	L	S	Material		B	L	S	Material	
			1.2311	1.2312				1.2311	1.2312				1.2311	1.2312
296	296	36	●	●	346	346	36	●	●	346	596	36	●	●
		46	●	●			46	●	●			46	●	●
		56	●	●			56	●	●			56	●	●
		66	●	●			66	●	●			66	●	●
		76	●	●			76	●	●			76	●	●
		86	●	●			86	●	●			86	●	●
		96	●	●			96	●	●			96	●	●
		116	●	●			116	●	●			116	●	●
296	346	36	●	●	346	396	36	●	●	396	396	36	●	●
		46	●	●			46	●	●			46	●	●
		56	●	●			56	●	●			56	●	●
		66	●	●			66	●	●			66	●	●
		76	●	●			76	●	●			76	●	●
		86	●	●			86	●	●			86	●	●
		96	●	●			96	●	●			96	●	●
		116	●	●			116	●	●			116	●	●
296	396	36	●	●	346	446	36	●	●	396	446	36	●	●
		46	●	●			46	●	●			46	●	●
		56	●	●			56	●	●			56	●	●
		66	●	●			66	●	●			66	●	●
		76	●	●			76	●	●			76	●	●
		86	●	●			86	●	●			86	●	●
		96	●	●			96	●	●			96	●	●
		116	●	●			116	●	●			116	●	●
296	446	36	●	●	346	496	36	●	●	396	496	36	●	●
		46	●	●			46	●	●			46	●	●
		56	●	●			56	●	●			56	●	●
		66	●	●			66	●	●			66	●	●
		76	●	●			76	●	●			76	●	●
		86	●	●			86	●	●			86	●	●
		96	●	●			96	●	●			96	●	●
		116	●	●			116	●	●			116	●	●
296	496	36	●	●	346	546	36	●	●	396	546	36	●	●
		46	●	●			46	●	●			46	●	●
		56	●	●			56	●	●			56	●	●
		66	●	●			66	●	●			66	●	●
		76	●	●			76	●	●			76	●	●
		86	●	●			86	●	●			86	●	●
		96	●	●			96	●	●			96	●	●
		116	●	●			116	●	●			116	●	●

Piastre P - P Plates

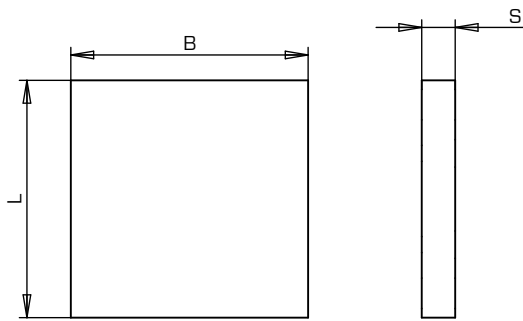

Fresato Milled	B/L	+ 0.2
		+ 0.3

Rettificato Grinded	S	+ 0.2
		+ 0.3

B	L	S	Material	
			1.2311	1.2312
396	546	86	●	●
		96	●	●
		116	●	●
		136	●	
396	596	36	●	●
		46	●	●
		56	●	●
		66	●	●
		76	●	●
		86	●	●
		96	●	●
		116	●	●
396	696	36	●	●
		46	●	●
		56	●	●
		66	●	●
		76	●	●
		86	●	●
		96	●	●
		116	●	●
446	446	46	●	●
		56	●	●
		66	●	●
		76	●	●
		86	●	●
		96	●	●
		116	●	●
		136	●	
		156	●	
		446	496	46
56	●			●
66	●			●
76	●			●
86	●			●
96	●			●
116	●			●
136	●			
156	●			

B	L	S	Material	
			1.2311	1.2312
446	546	46	●	●
		56	●	●
		66	●	●
		76	●	●
		86	●	●
		96	●	●
		116	●	●
		136	●	
446	596	46	●	●
		56	●	●
		66	●	●
		76	●	●
		86	●	●
		96	●	●
		116	●	●
		136	●	
446	696	46	●	●
		56	●	●
		66	●	●
		76	●	●
		86	●	●
		96	●	●
		116	●	●
		136	●	
		156	●	
		496	496	46
56	●			●
66	●			●
76	●			●
86	●			●
96	●			●
116	●			●
136	●			
496	546	46	●	●
		56	●	●
		66	●	●
		76	●	●
		76	●	●

B	L	S	Material	
			1.2311	1.2312
496	546	86	●	●
		96	●	●
		116	●	●
		136	●	
		156	●	
496	596	46	●	●
		56	●	●
		66	●	●
		76	●	●
		86	●	●
		96	●	●
		116	●	●
		136	●	
496	696	46	●	●
		56	●	●
		66	●	●
		76	●	●
		86	●	●
		96	●	●
		116	●	●
		136	●	

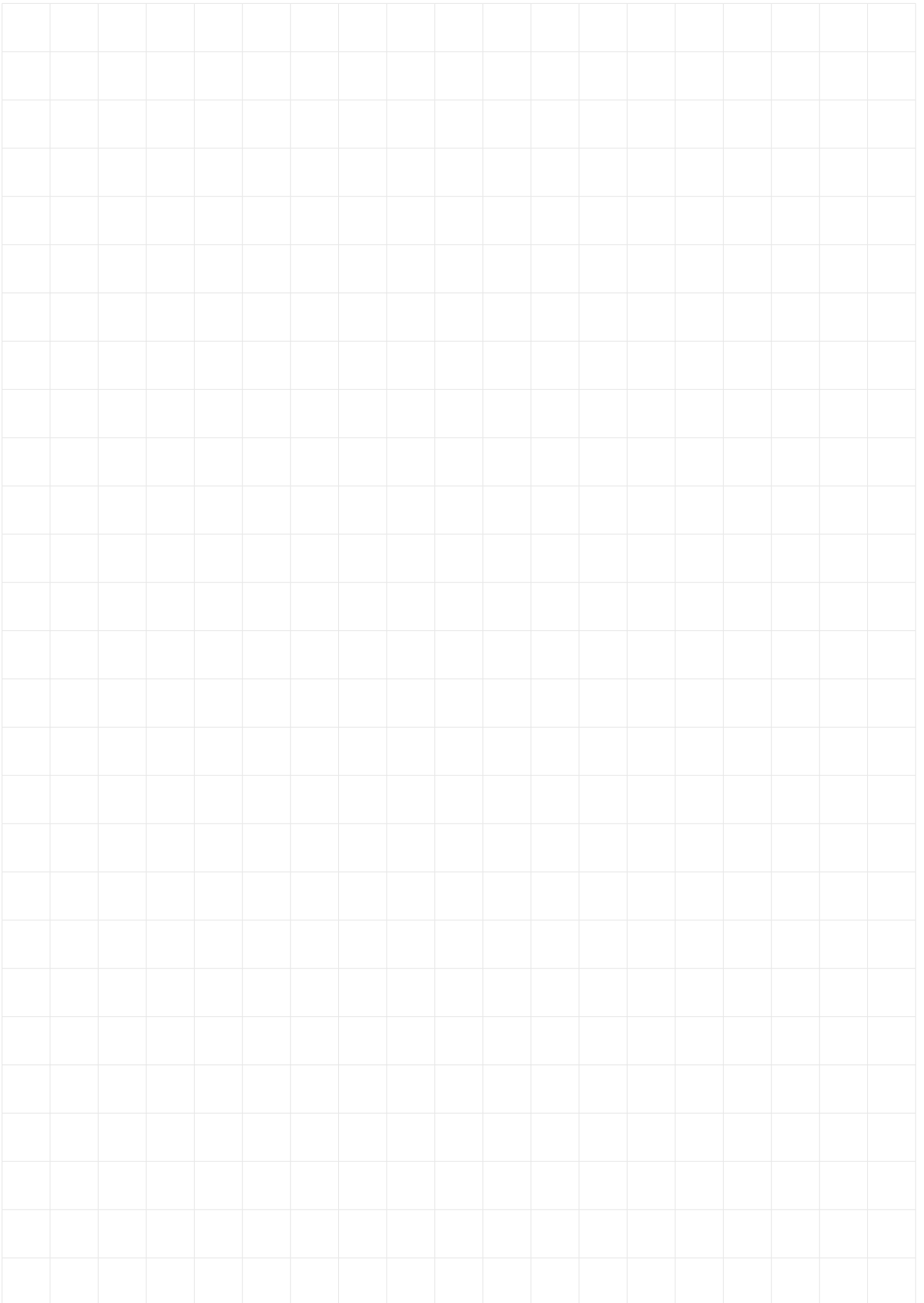

**PIASTRE PORTASTAMPI
MOULD BASES PLATES**



Materiali non a catalogo - Custom materials

Tecnostar, a richiesta, offre un'ampia scelta di materiali alternativi per le Piastre Portastampi:

Tecnostar can offer a wide selection of alternative materials for mould bases plates upon request:

Materiali Disponibili Available Materials							
1.2083	1.2085	1.2312	1.2343	1.2344	1.2379	1.2714	1.2738
●	●	●	●	●	●	●	●

Dimensioni non a catalogo - Custom dimensions

La nostra offerta di personalizzazioni non si ferma alla sola scelta dei materiali.

Our range of customized features involves not only the materials.

Possiamo fornire piastre di dimensioni non presenti a catalogo secondo le richieste del cliente.

We can also provide custom dimension plates according to customers' needs.

Come lavorazioni sui lati B e L possiamo offrire solo il taglio o la fresatura.

The processing on sides B and L can be provided with a simple cut or milled.

Mentre lo spessore S può essere fresato o rettificato. Anche le forature per le viti di fissaggio e le sedi degli scorrimenti possono essere personalizzate secondo le necessità.

The plate thickness S can be milled or grinded. Furthermore, the holes for the fixing screws and the guiding areas can be modified according to the request.

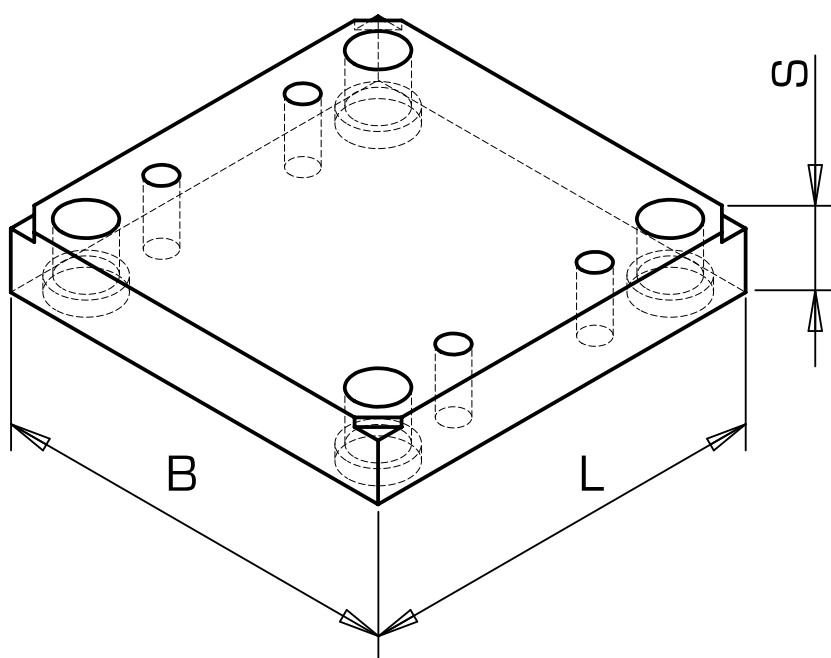

Acciaio 1.1730 - Steel 1.1730

Composizione chimica Chemical composition	C: 0,45/0,50 % Si: 0,15/0,40 % Mn: 0,60/0,80 %				
Proprietà dell'Acciaio Steel properties	Acciaio per utensili dalla superficie e nucleo duri. Tool steel with hard core and surface.				
Applicazioni Applications	Costruzione di stampi e portastampi per il settore plastico, stampaggio a iniezione e pressofusione. Mould plates for plastic moulds, injection moulding and dies.				
Stato alla consegna Supply condition	Trattamento di addolcimento, durezza massima 207 HB Soft annealing max. 207 HB				
Espansione Termica Thermal expansion	$\left(\frac{10^{-6} \cdot m}{m \cdot k} \right)$	$\frac{20-100^{\circ}\text{C}}{12,5}$	$\frac{20-200^{\circ}\text{C}}{13,0}$	$\frac{20-300^{\circ}\text{C}}{13,6}$	$\frac{20-400^{\circ}\text{C}}{14,1}$
Conduttività termica Thermal conductivity	$\left(\frac{W}{m \cdot k} \right)$	$\frac{20^{\circ}\text{C}}{44,9}$	$\frac{300^{\circ}\text{C}}{41,9}$		
Ricottura di lavorabilità Soft annealing	Temperatura: 680-710 °C Raffreddamento: in forno Durezza: max. 207 HB Temperature: 680-710 °C Cooling: oven Hardness: max. 207 HB				
Ricottura di distensione Stress relief annealing	Temperatura: 600-650 °C Raffreddamento: in forno Temperature: 600-650 °C Cooling: oven				
Temperatura Hardening	Temperatura: 800-850 °C Raffreddamento: acqua Temperature: 800-850 °C Cooling: water				

Diagramma di ciclo termico
Thermal cycle diagram



Diagramma di trasformazione durante raffreddamento continuo
Continuous cooling transformation diagram



Diagramma di rinvenimento
Tempering diagram

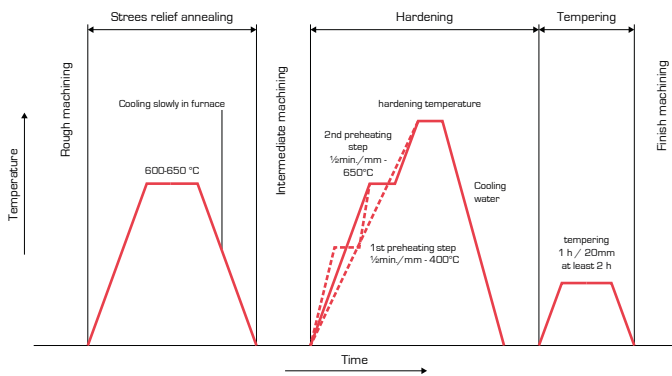

Acciaio 1.2311 - Steel 1.2311

Composizione chimica Chemical composition	C: 0,45/0,50 % Mn: 1,50 % Cr: 1,90 % Mo: 0,20 %				
Proprietà dell'Acciaio Steel properties	Buona lavorabilità, migliore lucidatura rispetto a 1.2312 Good machining, better polishing than 1.2312				
Applicazioni Applications	Acciaio per stampaggio ad iniezione. Steel for injection moulds.				
Stato alla consegna Supply condition	Trattamento di addolcimento e rinvenimento, 950-1100 N/mm ² Quenched and tempered, 950-1100 N/mm ²				
Espansione Termica Thermal expansion	$\left(\frac{10^{-6} \cdot m}{m \cdot k} \right)$	$\frac{20-100^{\circ}C}{12,1}$	$\frac{20-200^{\circ}C}{12,7}$	$\frac{20-300^{\circ}C}{13,2}$	$\frac{20-400^{\circ}C}{13,6}$
Conduktività termica Thermal conductivity	$\left(\frac{W}{m \cdot k} \right)$	$\frac{20^{\circ}C}{39,6}$	$\frac{300^{\circ}C}{39,2}$		
Ricottura di lavorabilità Soft annealing	Temperatura: 710-740 °C Raffreddamento: in forno Durezza: max. 235 HB Temperature: 710-740 °C Cooling: oven Hardness: max. 235 HB				
Ricottura di distensione Stress relief annealing	Temperatura: 500-550 °C Raffreddamento: in forno Temperature: 500-550 °C Cooling: oven				
Tempratura Hardening	Temperatura: 800-850 °C Raffreddamento: olio a bagno caldo 180-220 °C Temperature: 800-850 °C Cooling: oil, hot bath 180-220 °C				

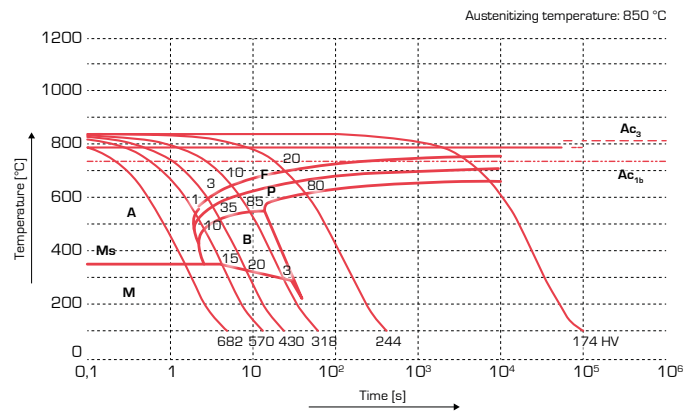
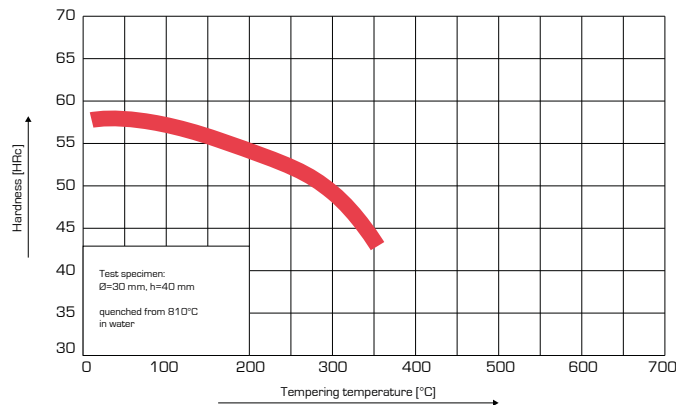
Diagramma di ciclo termico
Thermal cycle diagram



Diagramma di trasformazione durante raffreddamento continuo
Continuous cooling transformation diagram



Diagramma di rinvenimento
Tempering diagram

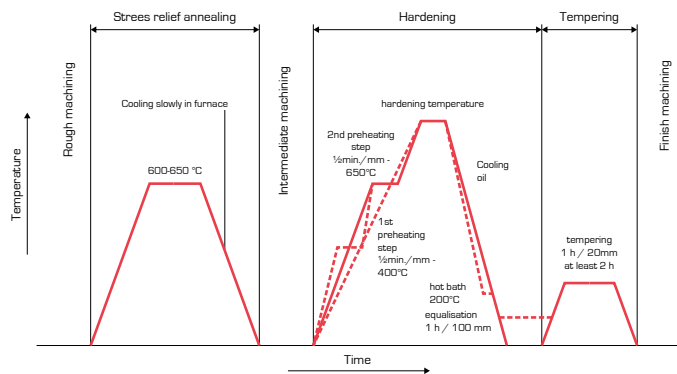

PF45

S	Material
22	1.1730

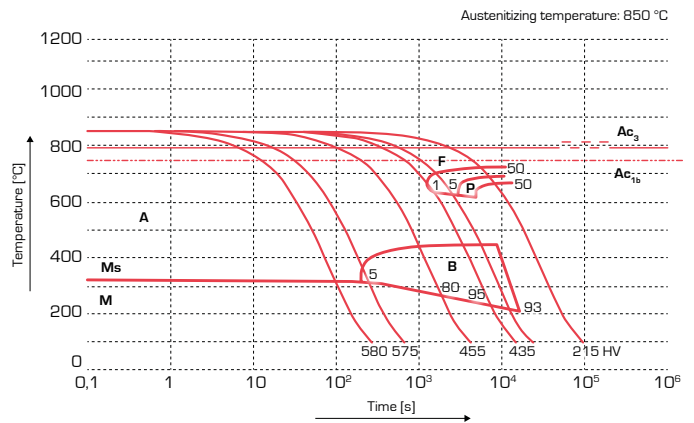
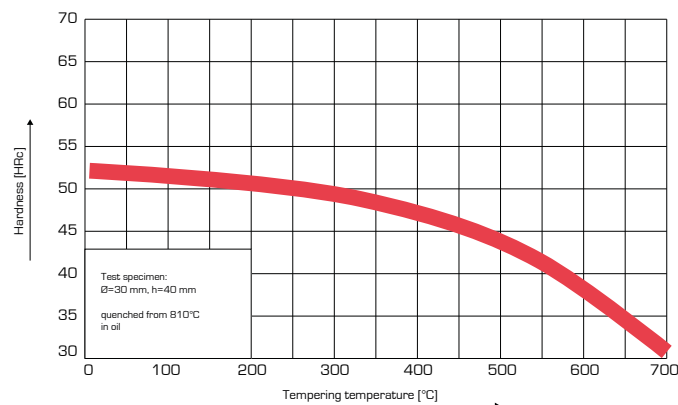
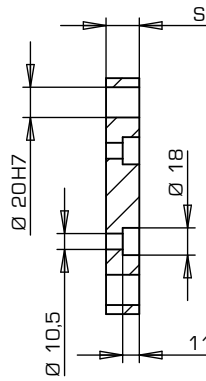
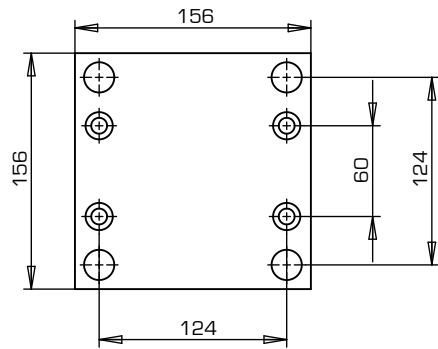

PD15

S	Material
22	1.1730

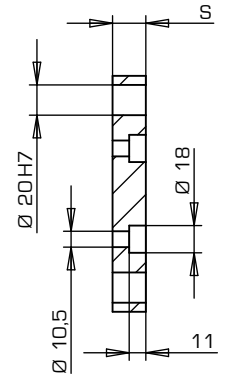
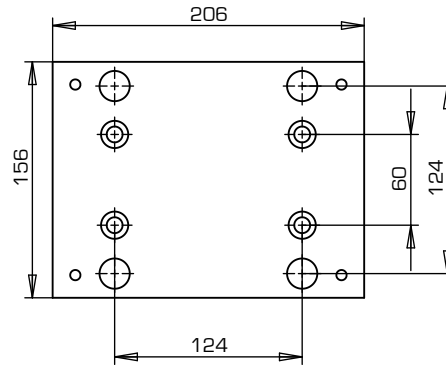

S50

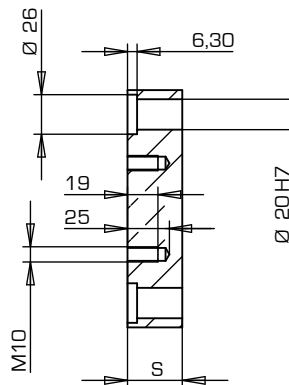
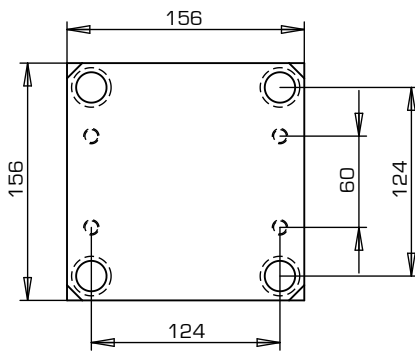

S	Material
27	1.1730 1.2311
36	
46	
56	
66	
76	

S60

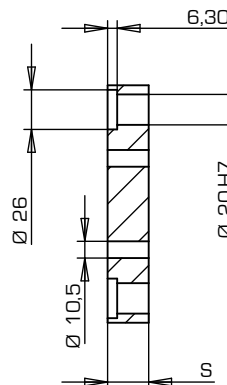
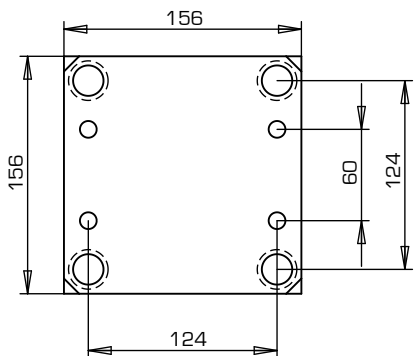

S	Material
27	1.1730 1.2311
36	
46	
56	
66	
76	

D70

S	Material
56	1.1730
76	
96	

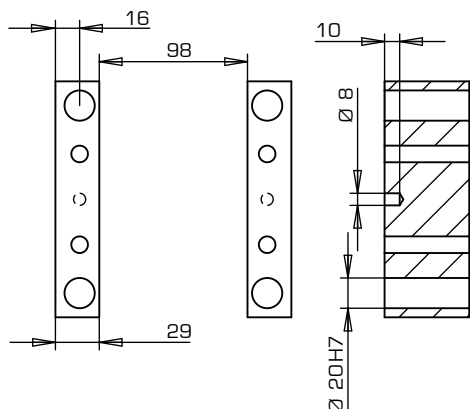

T80-T85/T90

S	Material
9+17	1.1730

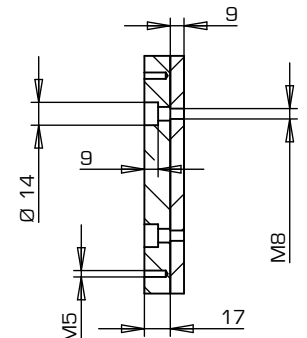
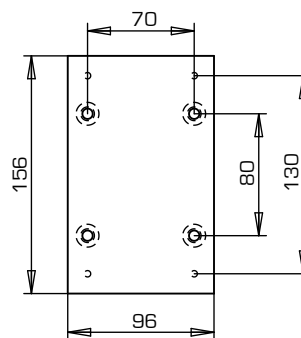

PF45

S	Material
22	1.1730

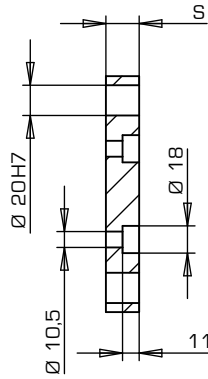
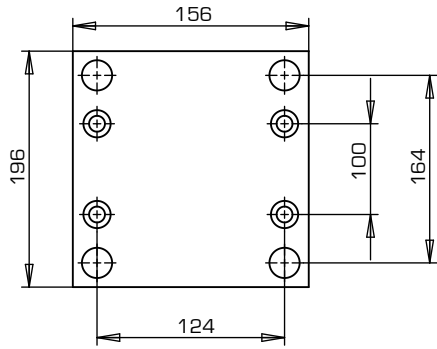

PD15

S	Material
22	1.1730

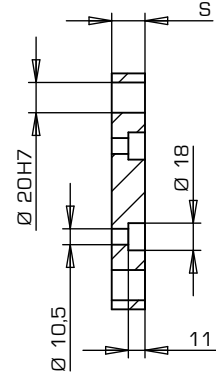
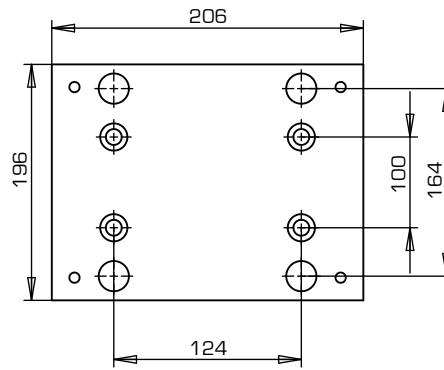

S50

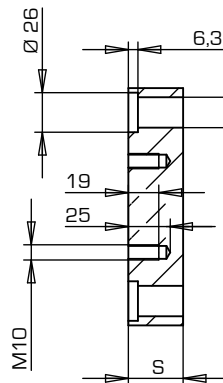
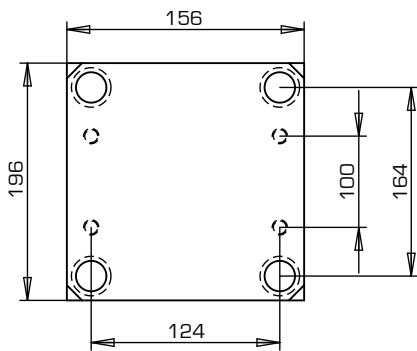

S	Material
27	1.1730 1.2311
36	
46	
56	
66	
76	

S60

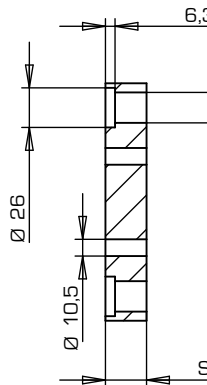
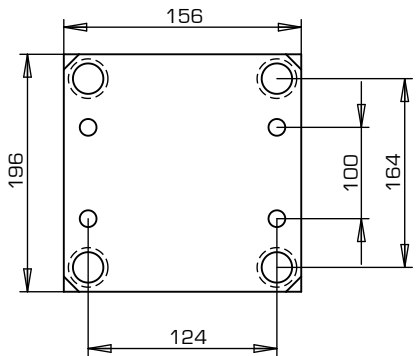

S	Material
27	1.1730 1.2311
36	
46	
56	
66	
76	

D70

S	Material
56	1.1730
76	
96	

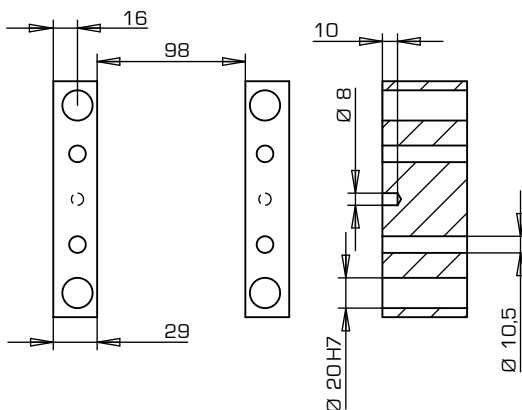

T80-T85/T90

S	Material
9+17	1.1730

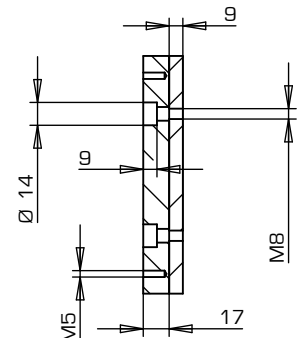
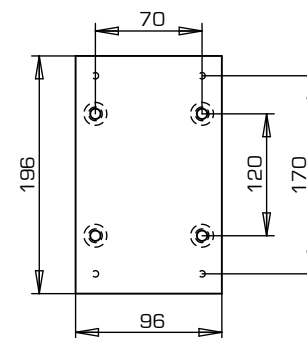

PF45

S	Material
27	1.1730

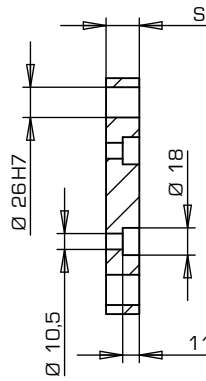
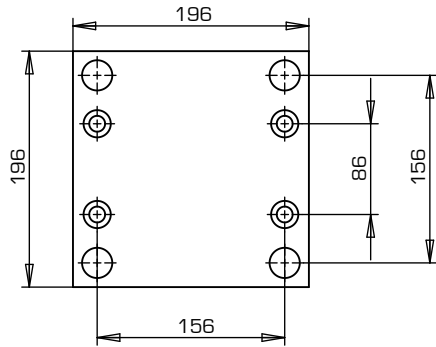

PD15

S	Material
27	1.1730

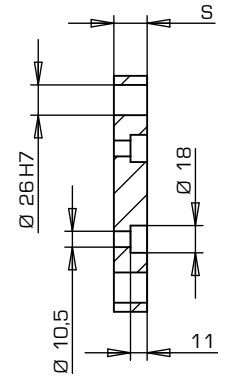
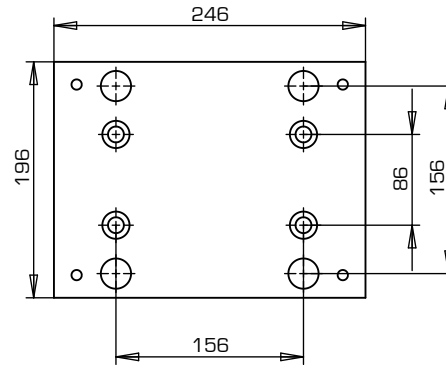

S50

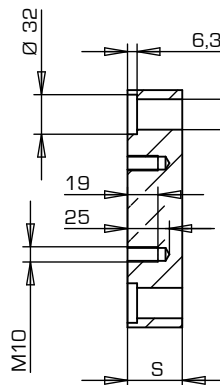
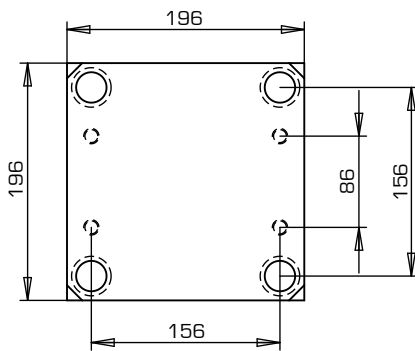

S	Material
27	1.1730 1.2311
36	
46	
56	
66	
76	
86	
96	

S60

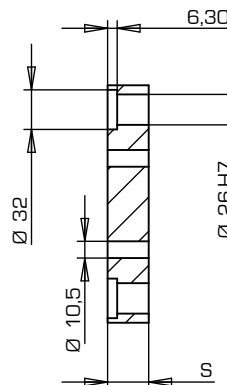
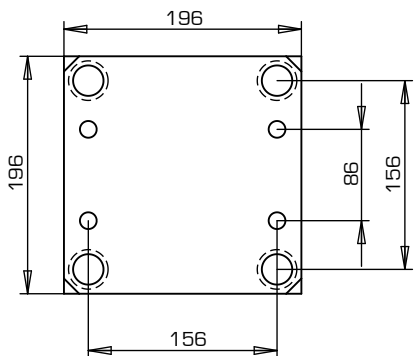

S	Material
27	1.1730 1.2311
36	
46	
56	
66	
76	
86	
96	

D70

S	Material
56	1.1730
76	
96	

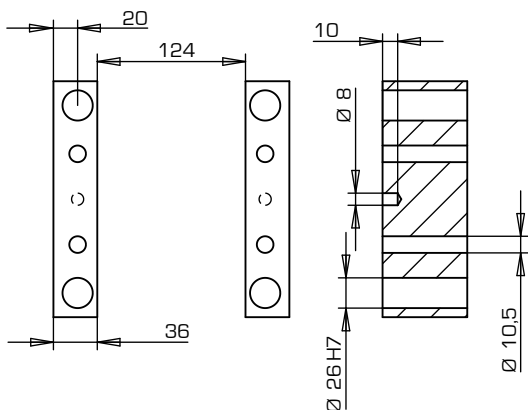

T80-T85/T90

S	Material
12+17	1.1730

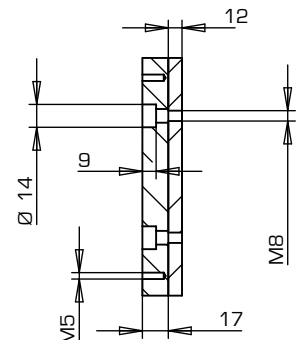
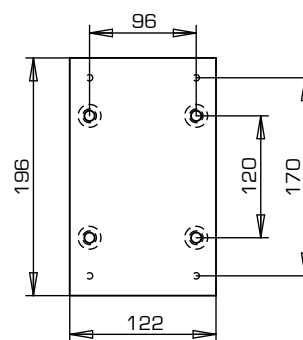

PF45

S	Material
27	1.1730

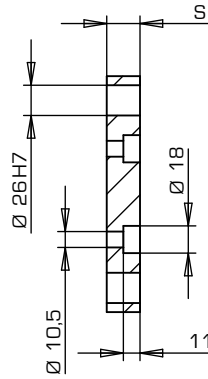
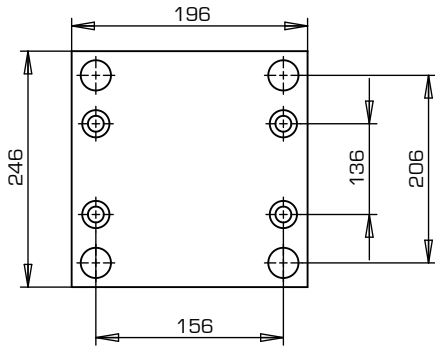

PD15

S	Material
27	1.1730

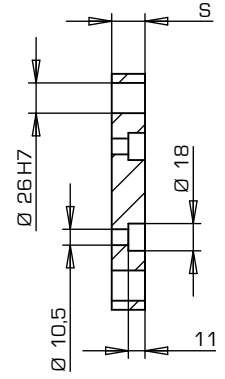
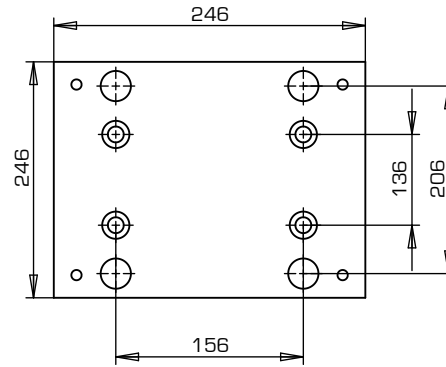

S50

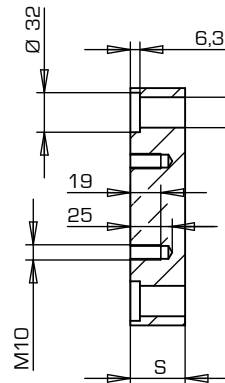
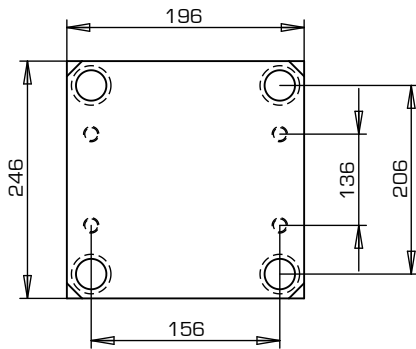

S	Material
27	1.1730 1.2311
36	
46	
56	
66	
76	
86	
96	

S60

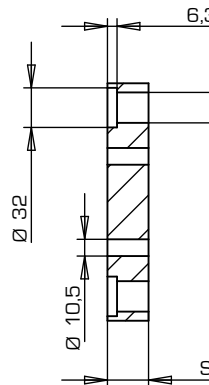
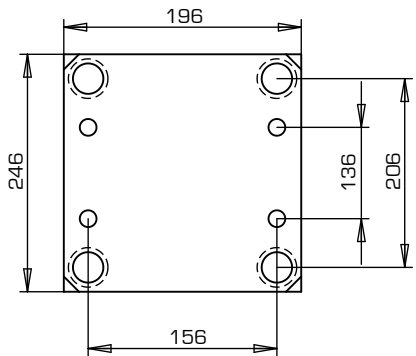

S	Material
27	1.1730 1.2311
36	
46	
56	
66	
76	
86	
96	

D70

S	Material
56	1.1730
76	
96	

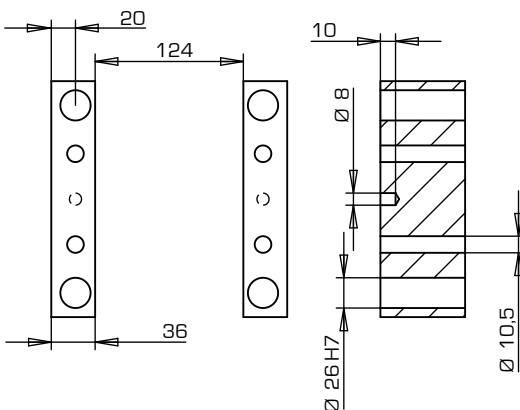

T80-T85/T90

S	Material
12+17	1.1730

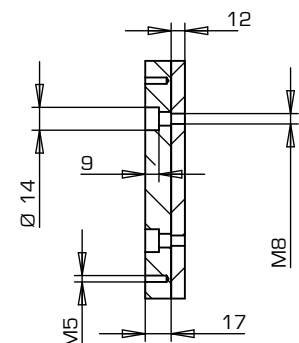
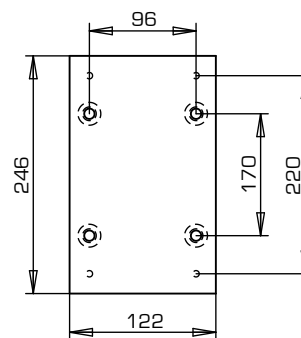

PF45

S	Material
27	1.1730

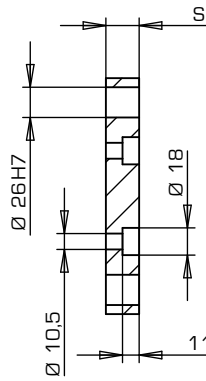
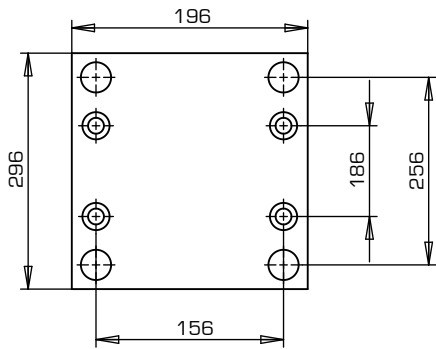

PD15

S	Material
27	1.1730

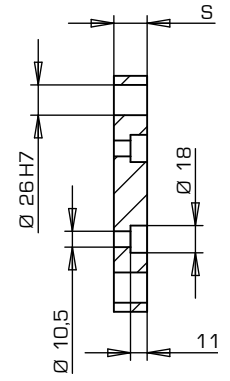
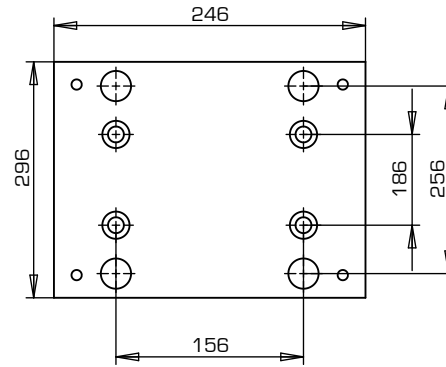

S50

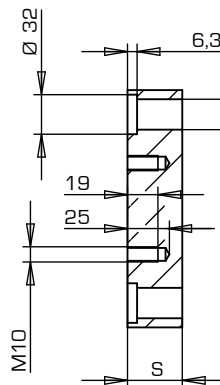
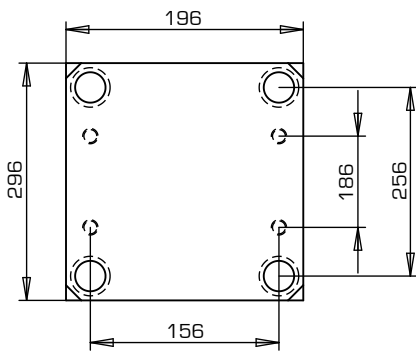

S	Material	
27	1.1730	1.2311
36		
46		
56		
66		
76		
86		
96		

S60

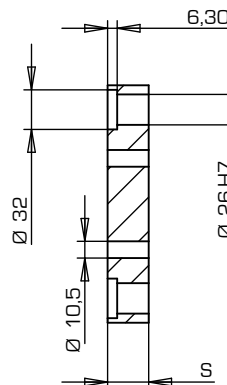
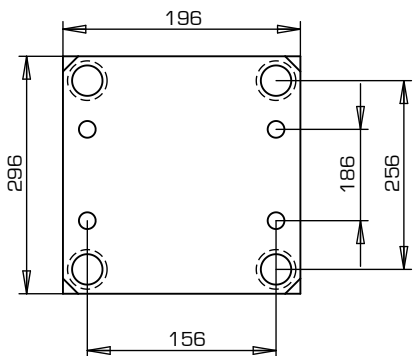

S	Material	
27	1.1730	1.2311
36		
46		
56		
66		
76		
86		
96		

D70

S	Material
56	1.1730
76	
96	

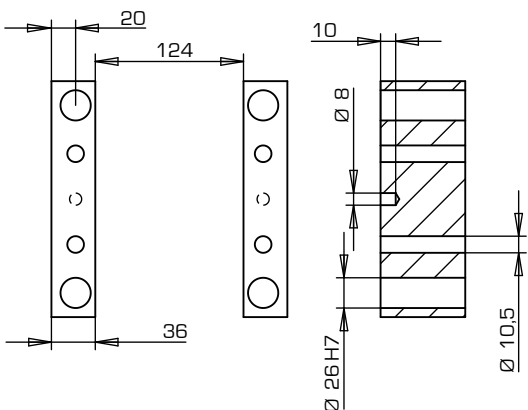

T80-T85/T90

S	Material
12+17	1.1730

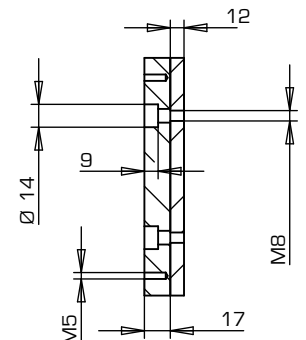
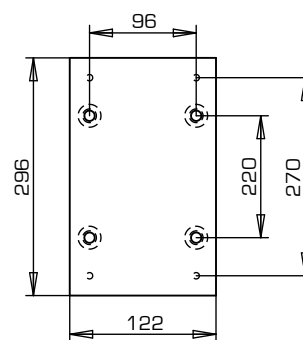

PF45

S	Material
27	1.1730

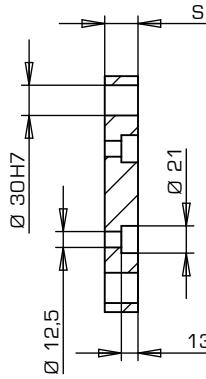
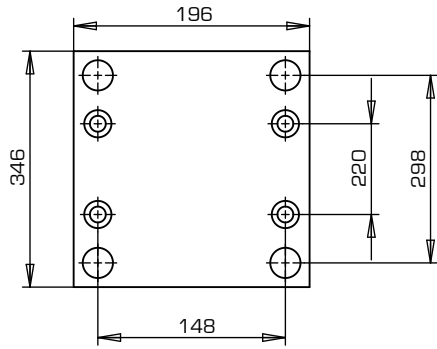

PD15

S	Material
27	1.1730

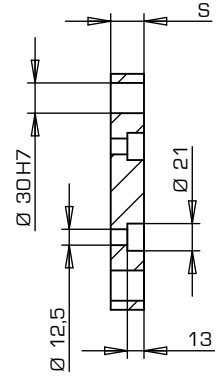
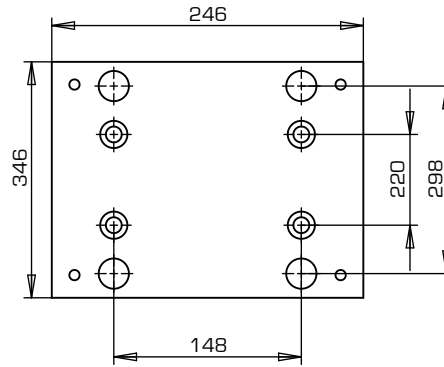

S50

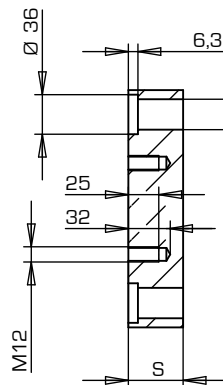
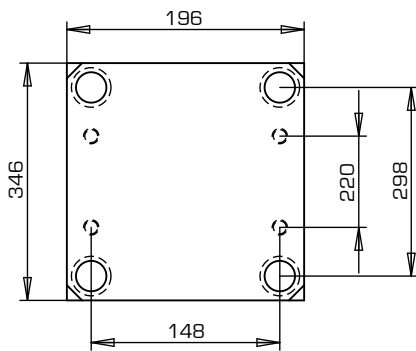

S	Material
27	1.1730 1.2311
36	
46	
56	
66	
76	
86	
96	

S60

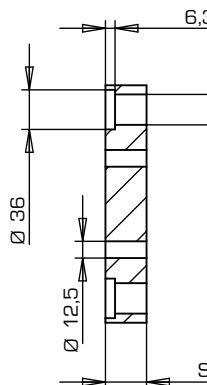
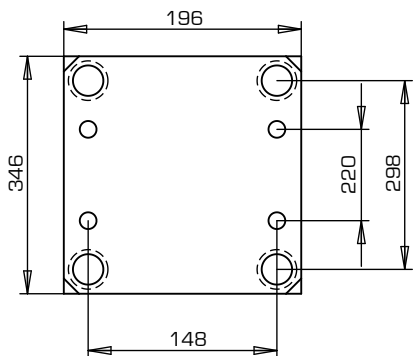

S	Material
27	1.1730 1.2311
36	
46	
56	
66	
76	
86	
96	

D70

S	Material
56	1.1730
76	
96	

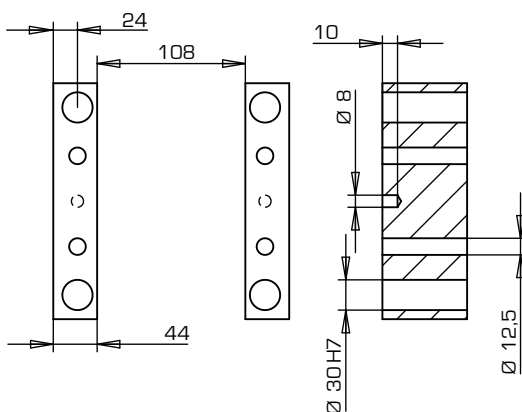

T80-T85/T90

S	Material
17+22	1.1730

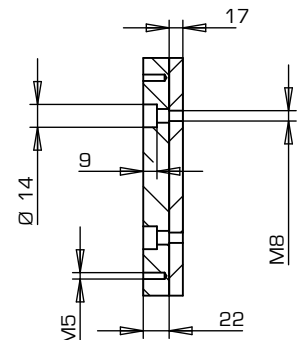
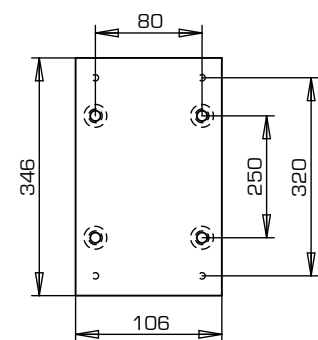

PF45

S	Material
27	1.1730

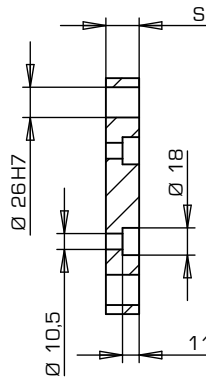
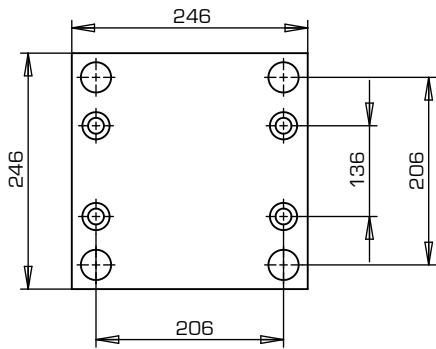

PD15

S	Material
27	1.1730

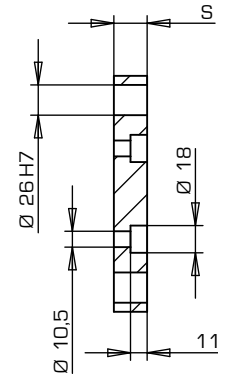
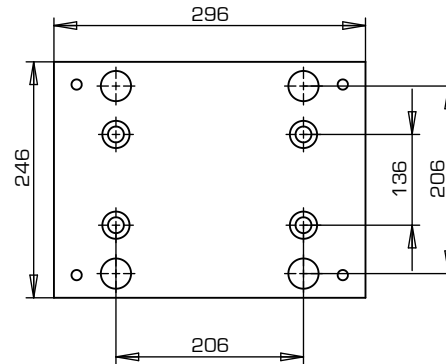

S50

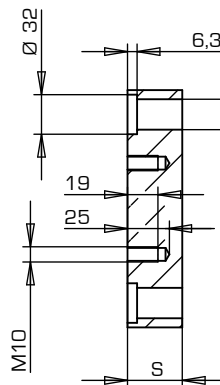
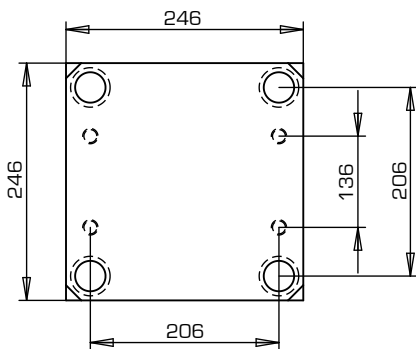

S	Material
27	1.1730 1.2311
36	
46	
56	
66	
76	
86	
96	

S60

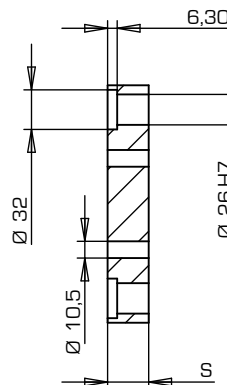
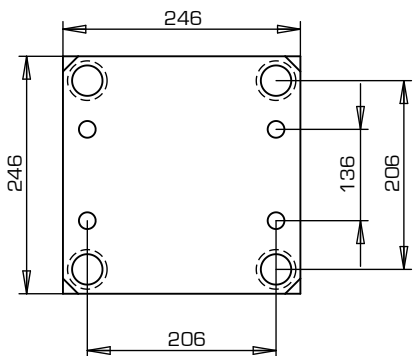

S	Material
27	1.1730 1.2311
36	
46	
56	
66	
76	
86	
96	

D70

S	Material
56	1.1730
76	
96	

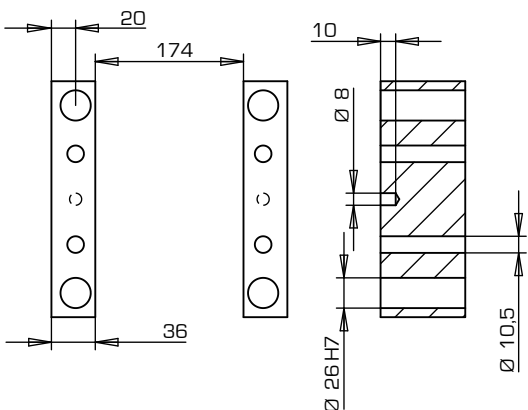

T80-T85/T90

S	Material
12+17	1.1730

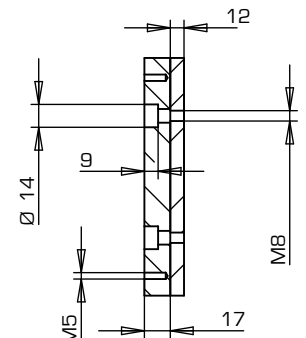
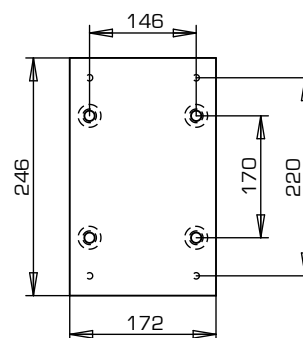

PF45

S	Material
27	1.1730

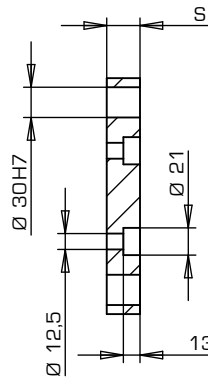
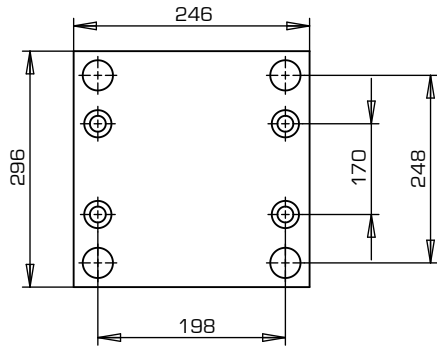

PD15

S	Material
27	1.1730

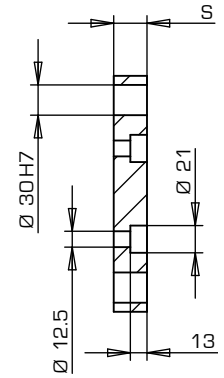
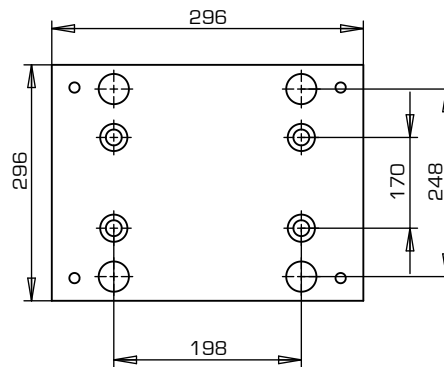

S50

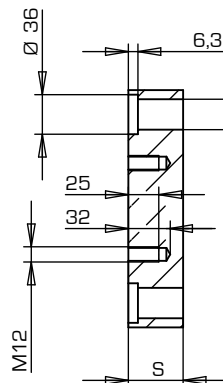
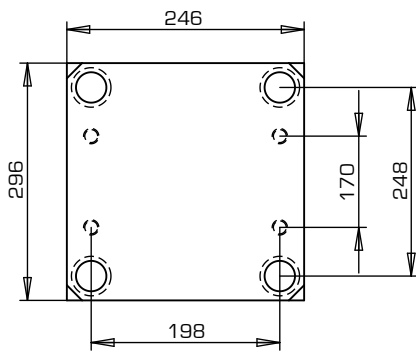

S	Material
27	1.1730 1.2311
36	
46	
56	
66	
76	
86	
96	

S60

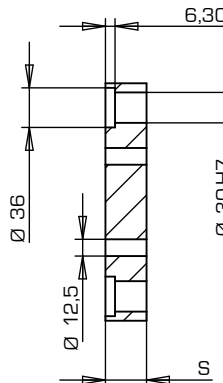
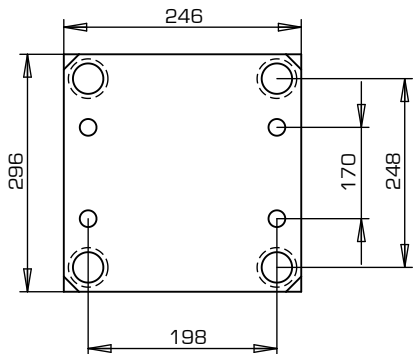

S	Material
27	1.1730 1.2311
36	
46	
56	
66	
76	
86	
96	

D70

S	Material
56	1.1730
76	
96	

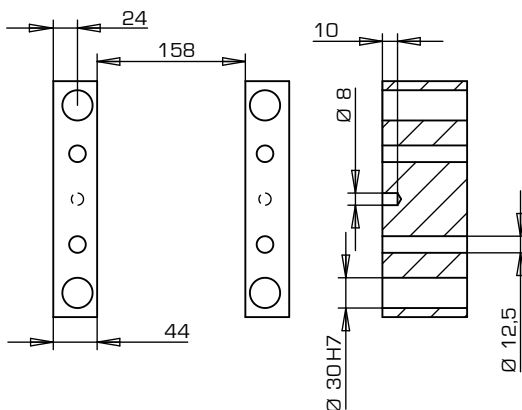

T80-T85/T90

S	Material
12+22	1.1730

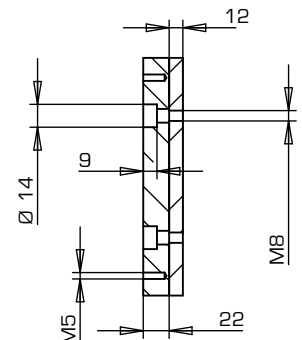
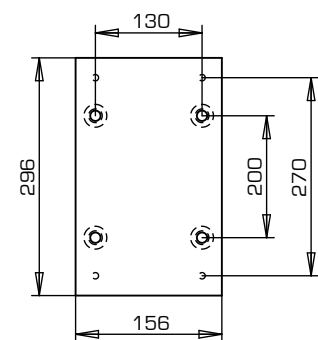

PF45

S	Material
27	1.1730

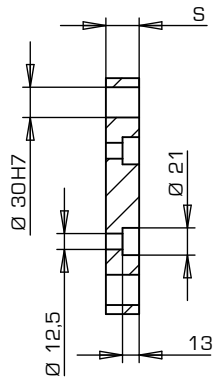
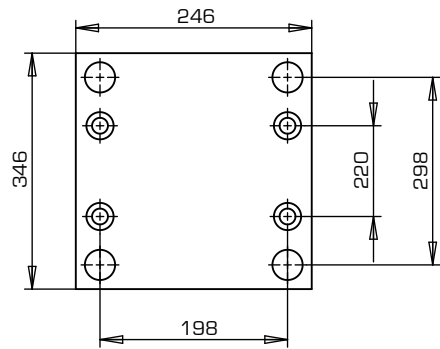

PD15

S	Material
27	1.1730

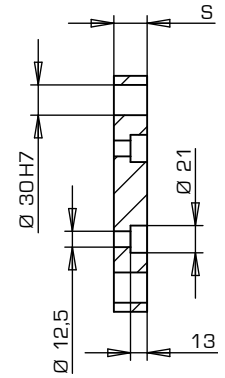
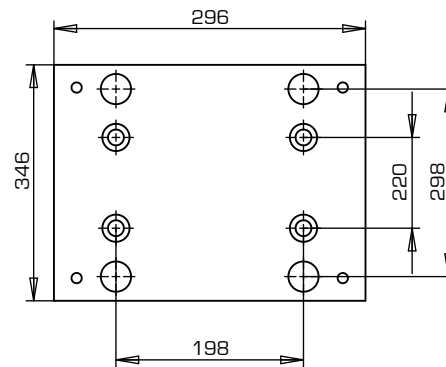

S50

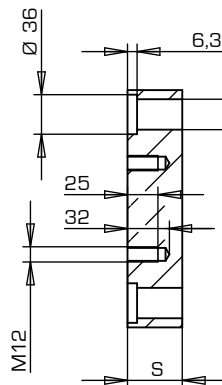
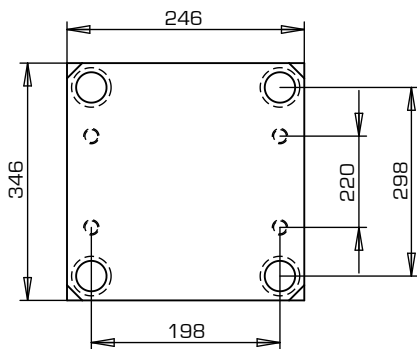

S	Material
27	1.1730 1.2311
36	
46	
56	
66	
76	
86	
96	

S60

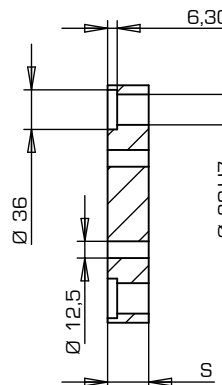
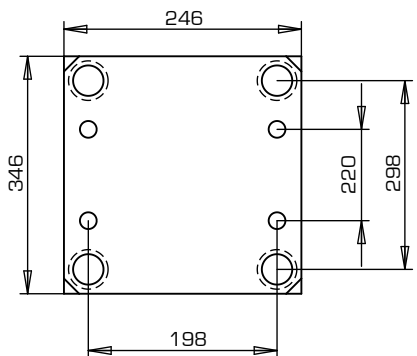

S	Material
27	1.1730 1.2311
36	
46	
56	
66	
76	
86	
96	

D70

S	Material
56	1.1730
76	
96	

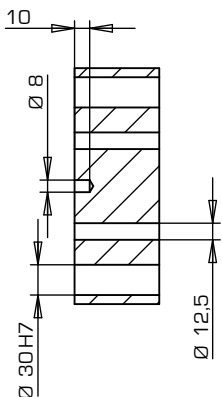
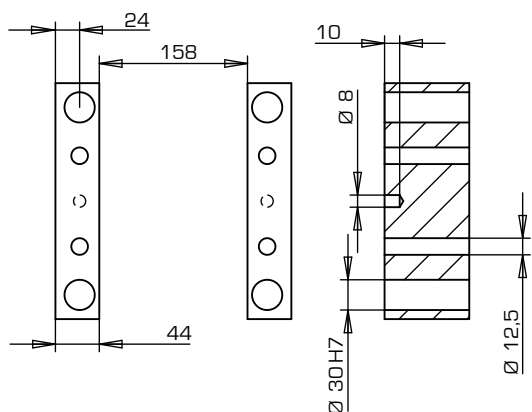

T80-T85/T90

S	Material
17+22	1.1730

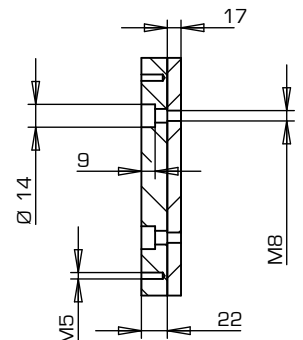
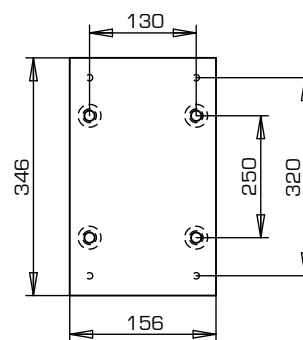

PF45

S	Material
27	1.1730

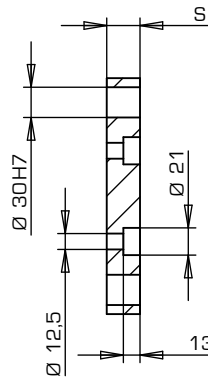
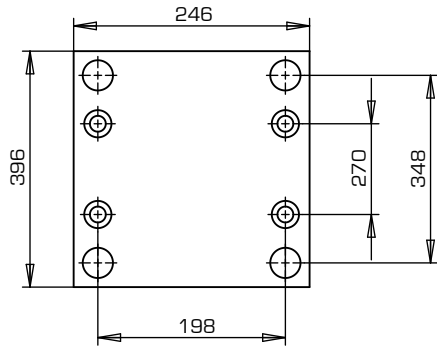

PD15

S	Material
27	1.1730

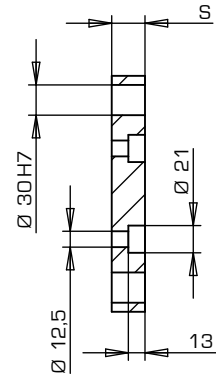
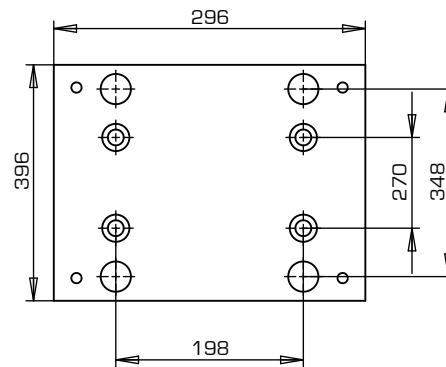

S50

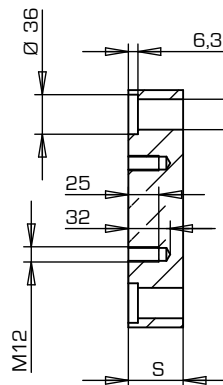
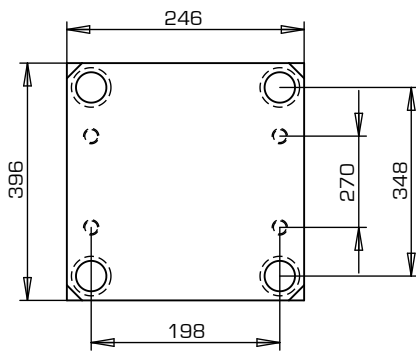

S	Material
27	1.1730 1.2311
36	
46	
56	
66	
76	
86	
96	

S60

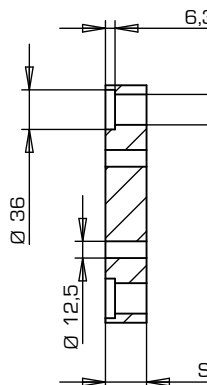
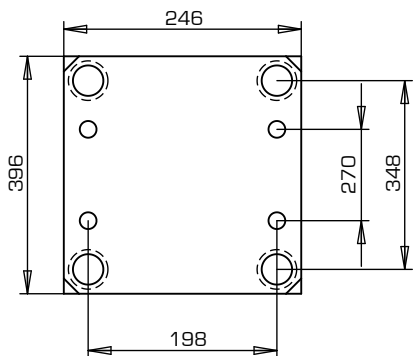

S	Material
27	1.1730 1.2311
36	
46	
56	
66	
76	
86	
96	

D70

S	Material
56	1.1730
76	
96	

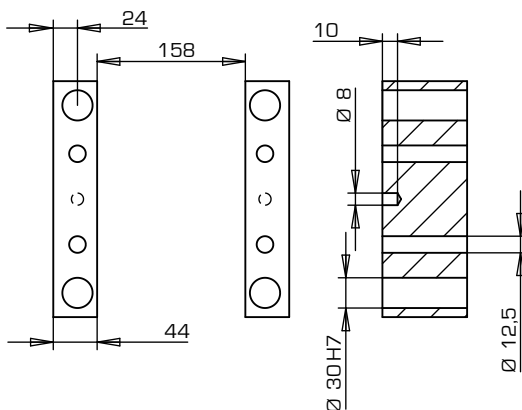

T80-T85/T90

S	Material
17+22	1.1730

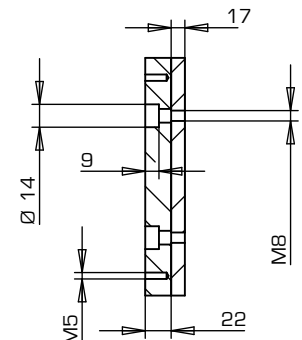
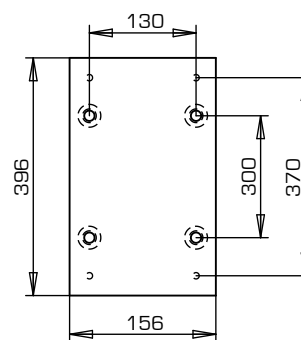

PF45

S	Material
27	1.1730

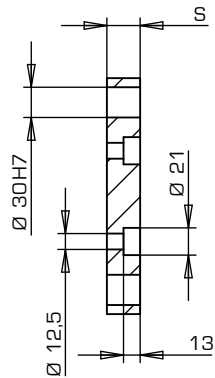
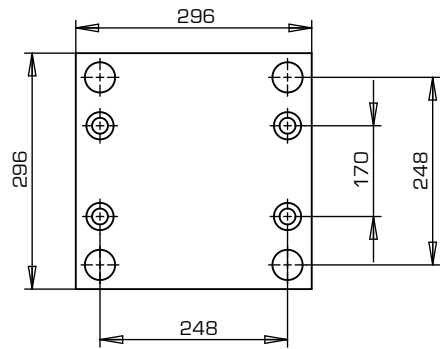

PD15

S	Material
27	1.1730

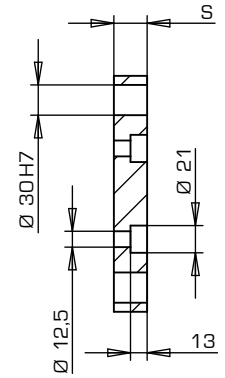
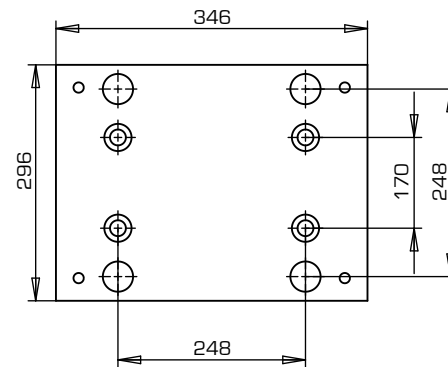

S50

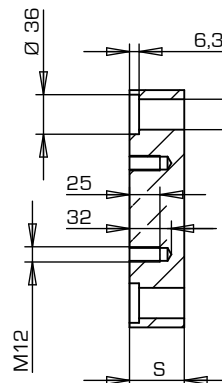
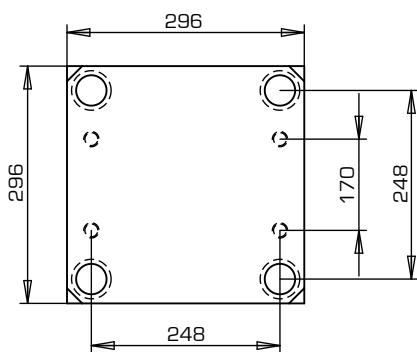

S	Material	
36	1.1730	1.2311
46		
56		
66		
76		
86		
96		
116		

S60

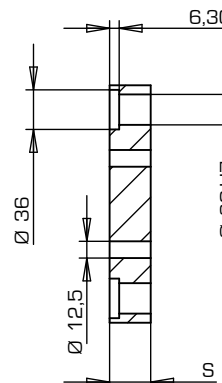
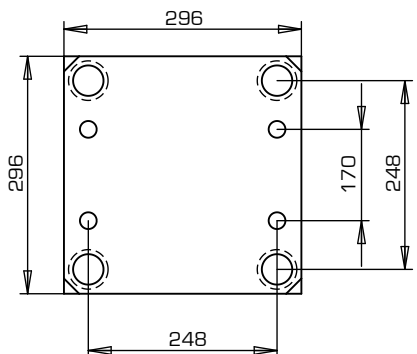

S	Material	
36	1.1730	1.2311
46		
56		
66		
76		
86		
96		
116		

D70

S	Material
56	1.1730
76	
96	
116	

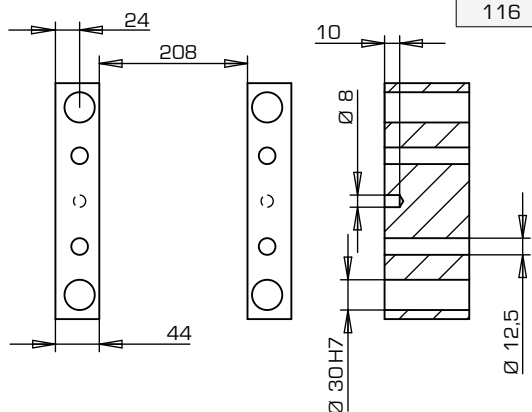

T80-T85/T90

S	Material
12+22	1.1730

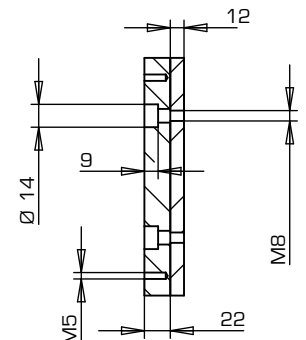
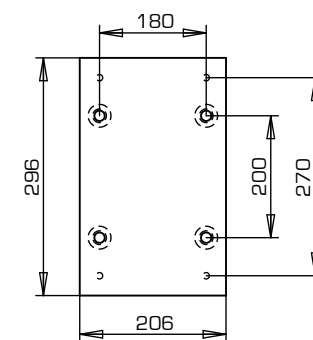

PF45

S	Material
27	1.1730

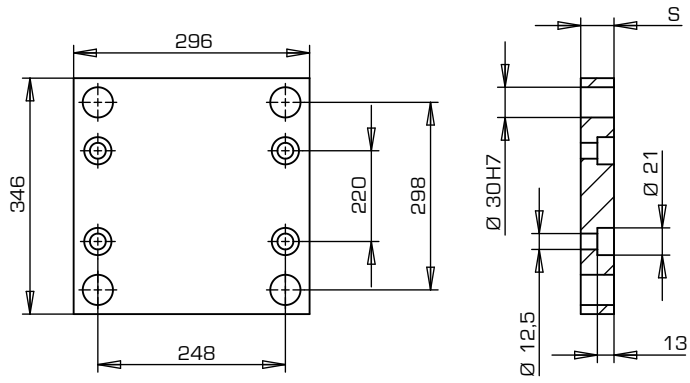

PD15

S	Material
27	1.1730

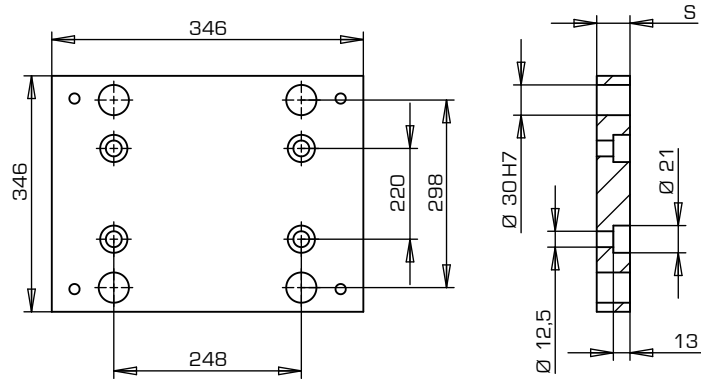

S50

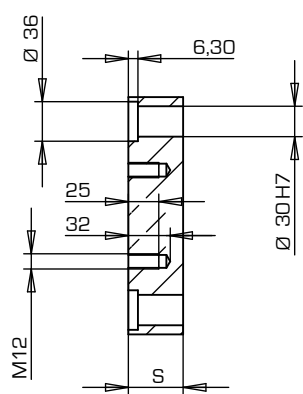
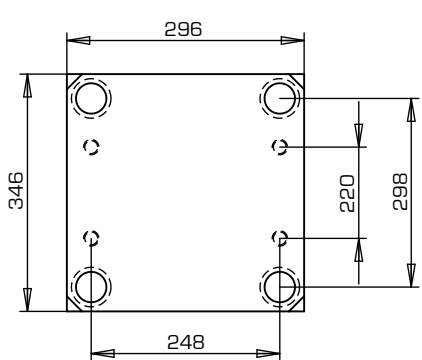

S	Material
36	1.1730 1.2311
46	
56	
66	
76	
86	
96	
116	

S60

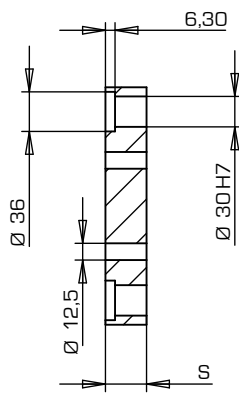
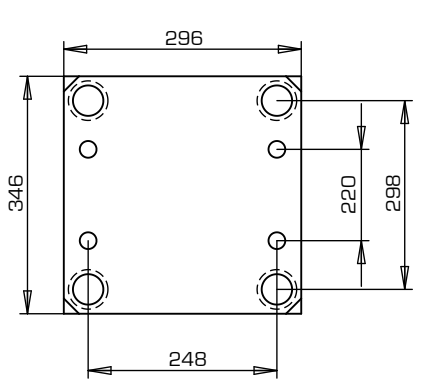

S	Material
36	1.1730 1.2311
46	
56	
66	
76	
86	
96	
116	

D70

S	Material
56	1.1730
76	
96	
116	

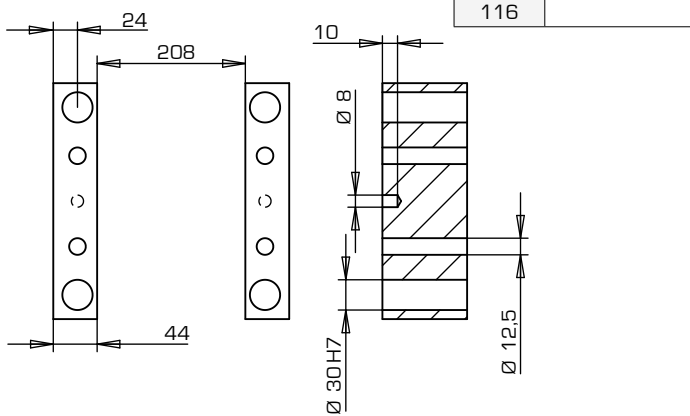

T80-T85/T90

S	Material
17+22	1.1730

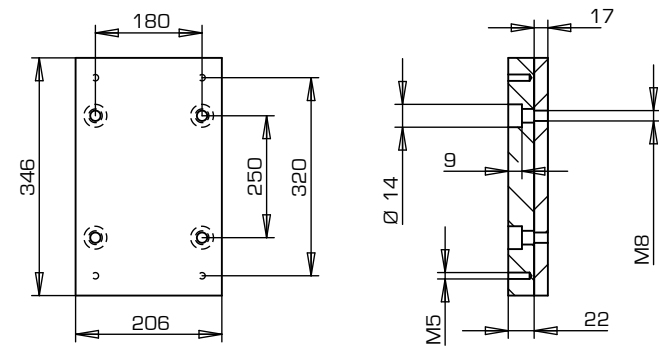

PF45

S	Material
27	1.1730

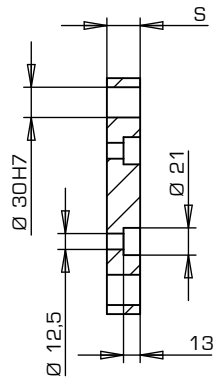
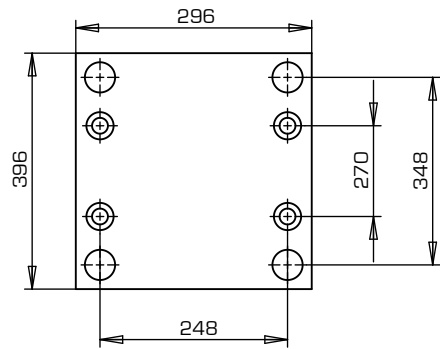

PD15

S	Material
27	1.1730

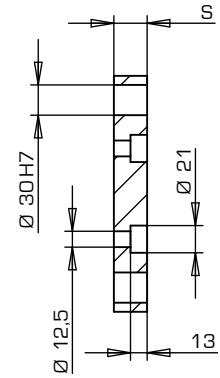
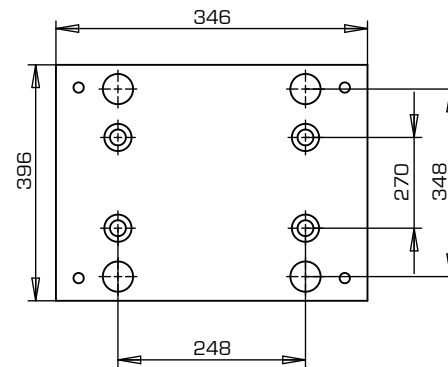

S50

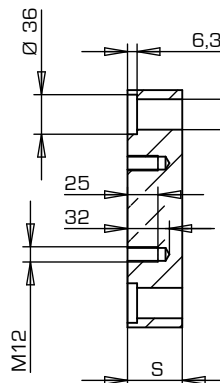
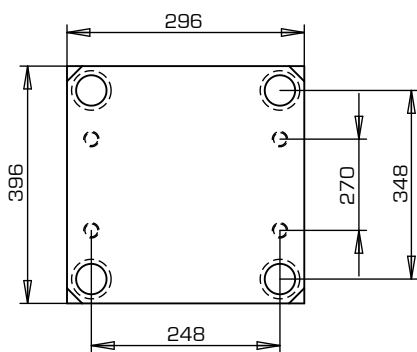

S	Material	
36	1.1730	1.2311
46		
56		
66		
76		
86		
96		
116		

S60

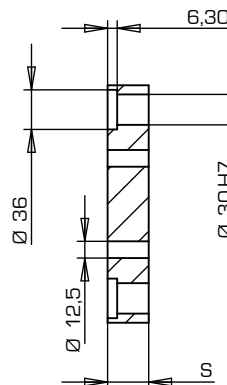
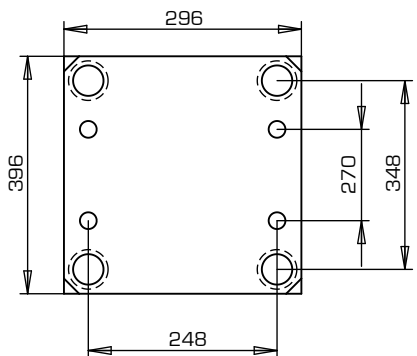

S	Material	
36	1.1730	1.2311
46		
56		
66		
76		
86		
96		
116		

D70

S	Material
56	1.1730
76	
96	
116	

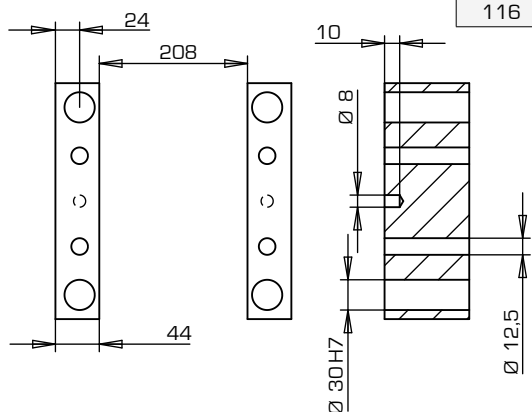

T80-T85/T90

S	Material
17+22	1.1730

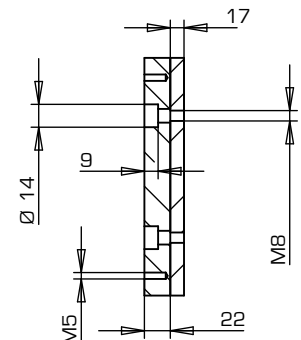
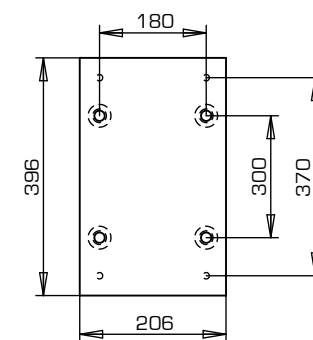

PF45

S	Material
27	1.1730

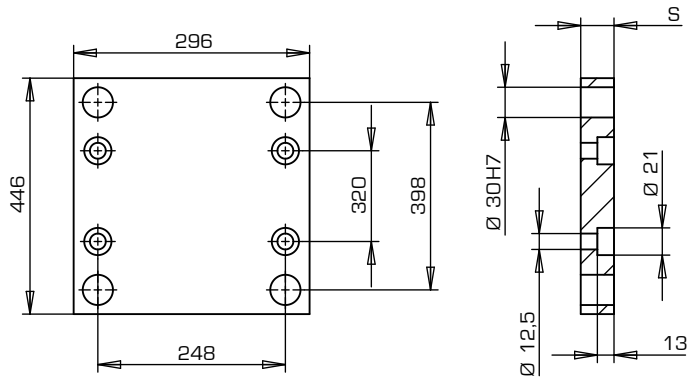

PD15

S	Material
27	1.1730

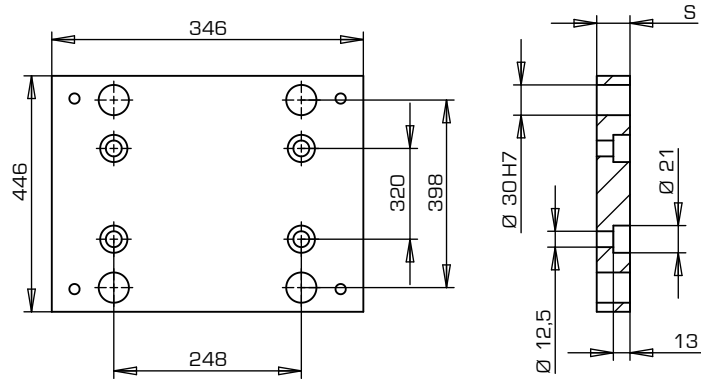

S50

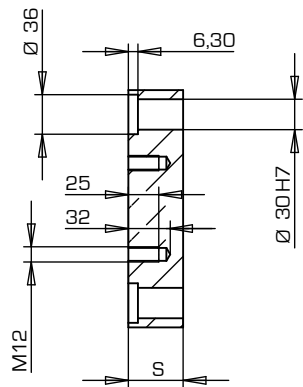
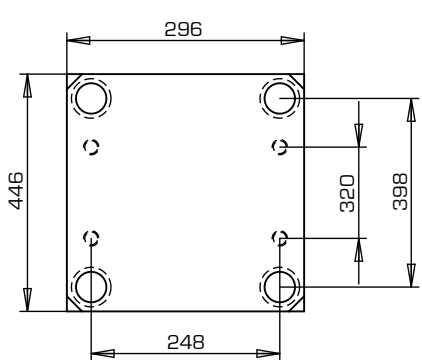

S	Material
36	1.1730 1.2311
46	
56	
66	
76	
86	
96	
116	

S60

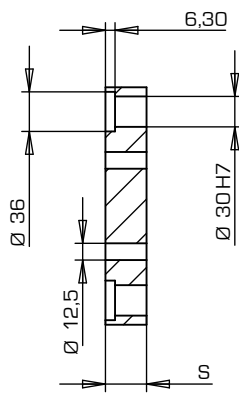
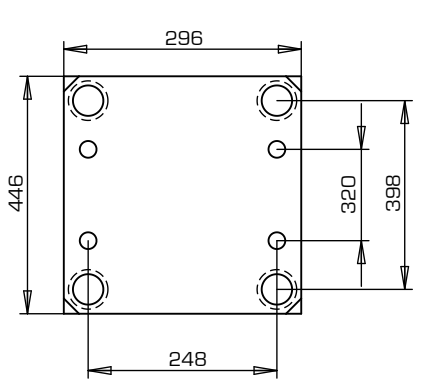

S	Material
36	1.1730 1.2311
46	
56	
66	
76	
86	
96	
116	

D70

S	Material
56	1.1730
76	
96	
116	

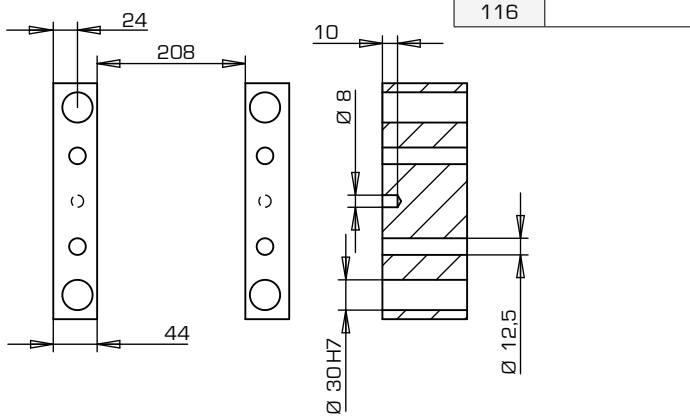

T80-T85/T90

S	Material
17+22	1.1730

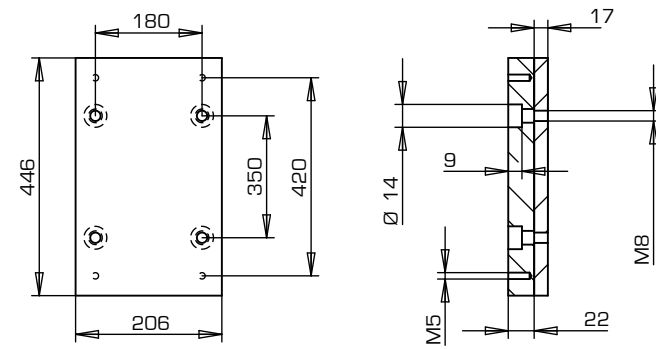

PF45

S	Material
27	1.1730

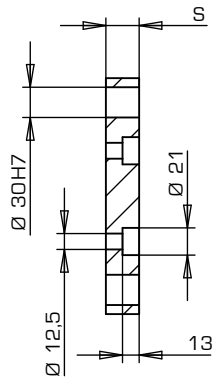
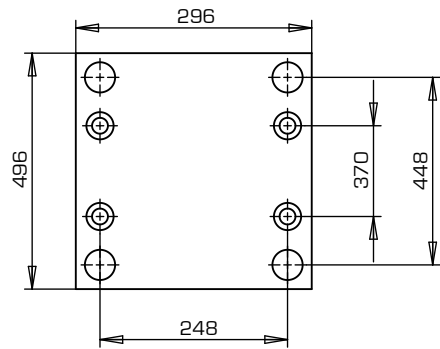

PD15

S	Material
27	1.1730

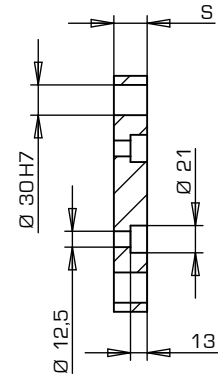
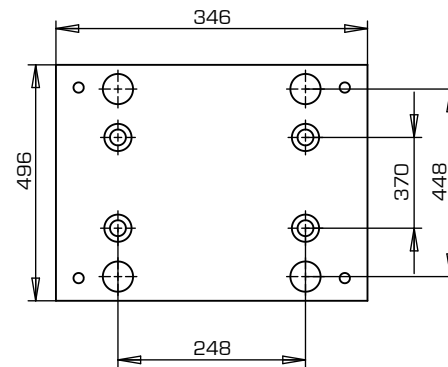

S50

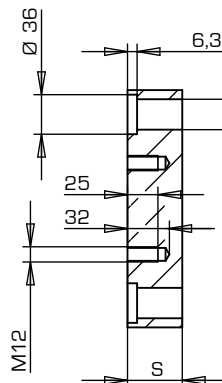
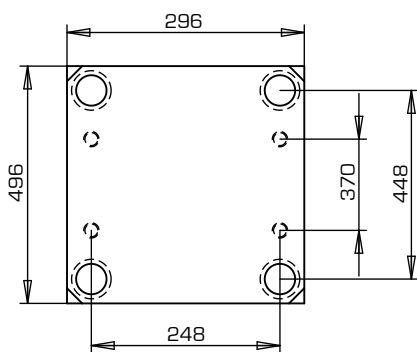

S	Material
36	1.1730 1.2311
46	
56	
66	
76	
86	
96	
116	

S60

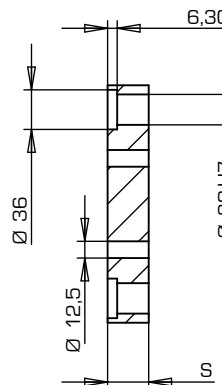
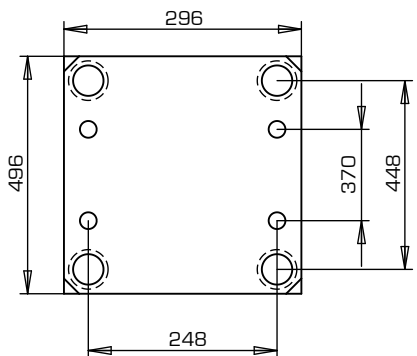

S	Material
36	1.1730 1.2311
46	
56	
66	
76	
86	
96	
116	

D70

S	Material
56	1.1730
76	
96	
116	

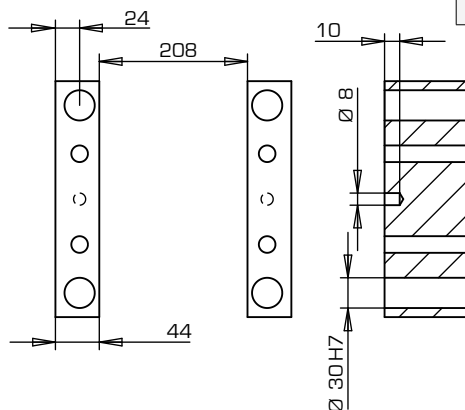

T80-T85/T90

S	Material
17+22	1.1730

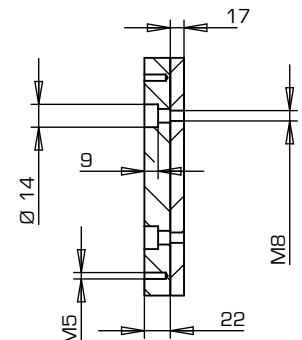
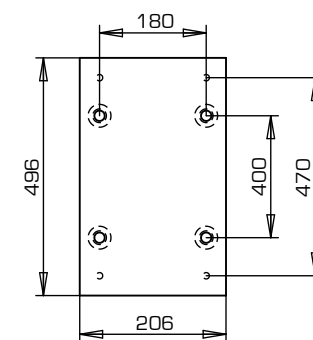

PF45

S	Material
27	1.1730

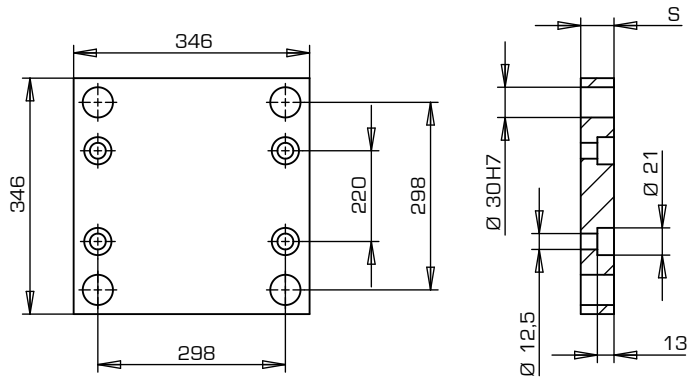

PD15

S	Material
27	1.1730

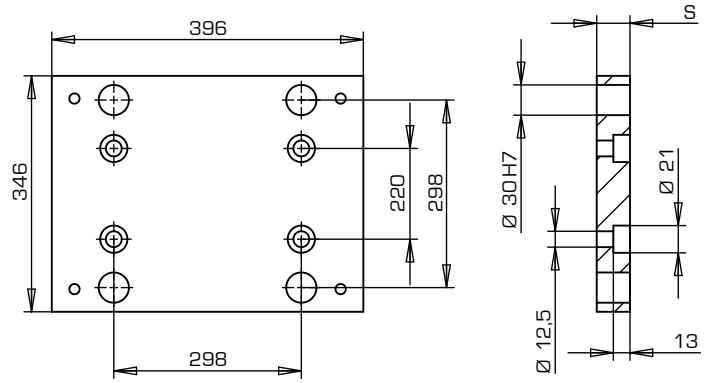

S50

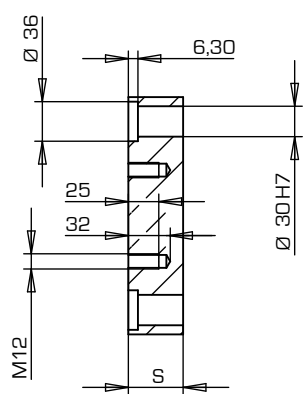
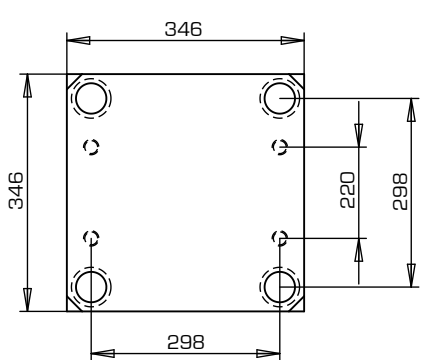

S	Material
36	1.1730 1.2311
46	
56	
66	
76	
86	
96	
116	

S60

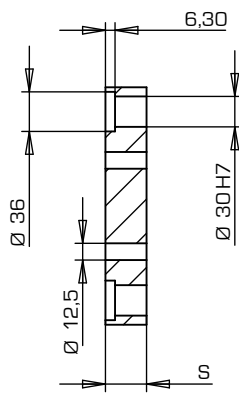
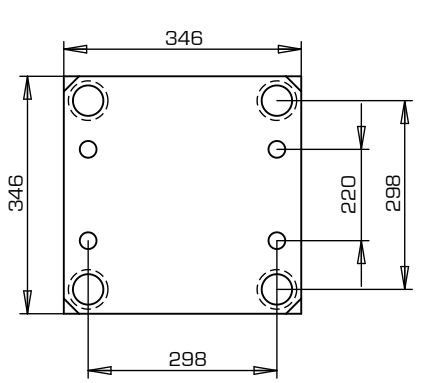

S	Material
36	1.1730 1.2311
46	
56	
66	
76	
86	
96	
116	

D70

S	Material
76	1.1730
96	
116	

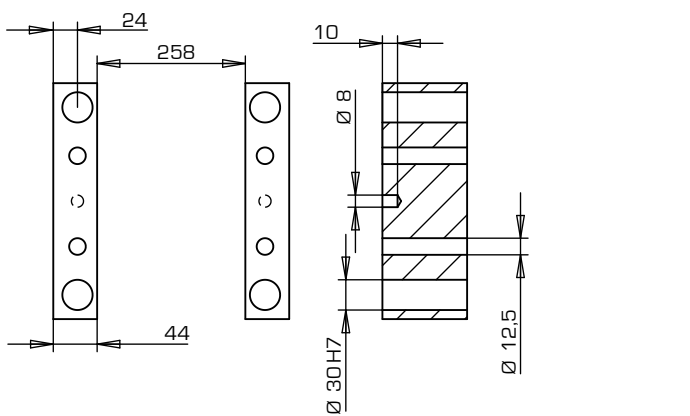

T80-T85/T90

S	Material
17+22	1.1730

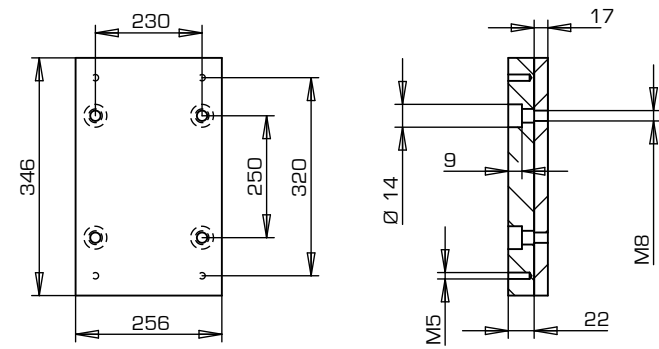

PF45

S	Material
27	1.1730

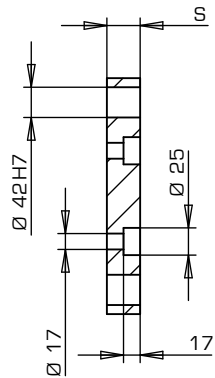
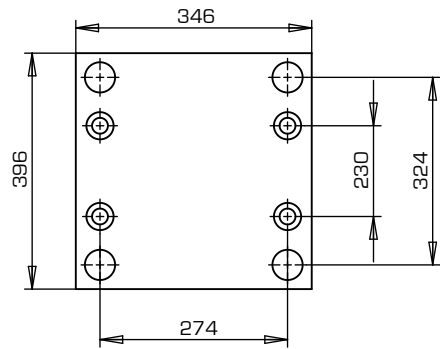

PD15

S	Material
27	1.1730

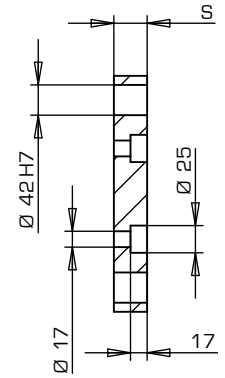
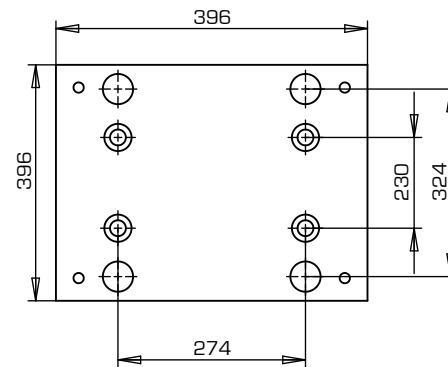

S50

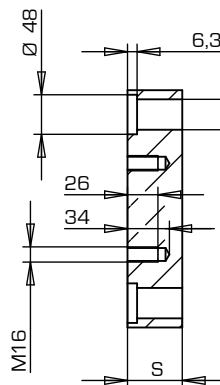
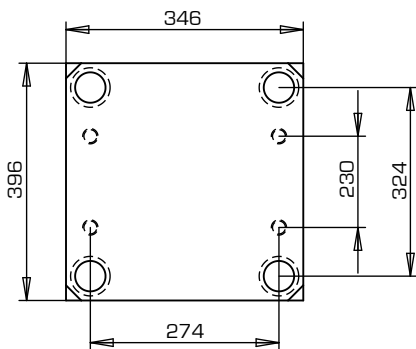

S	Material
36	1.1730 1.2311
46	
56	
66	
76	
86	
96	
116	

S60

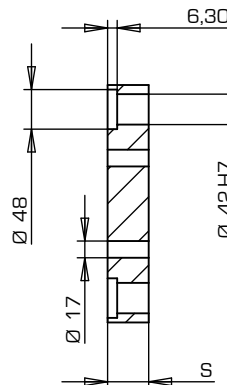
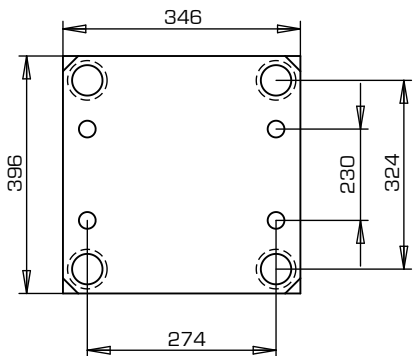

S	Material
36	1.1730 1.2311
46	
56	
66	
76	
86	
96	
116	

D70

S	Material
76	1.1730
96	
116	

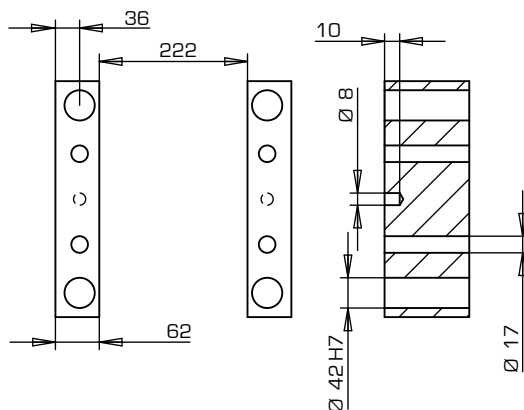

T80-T85/T90

S	Material
17+22	1.1730

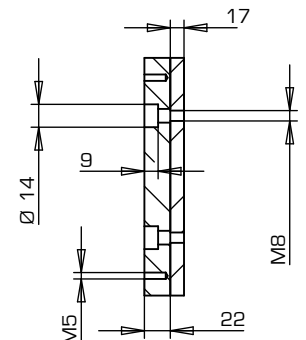
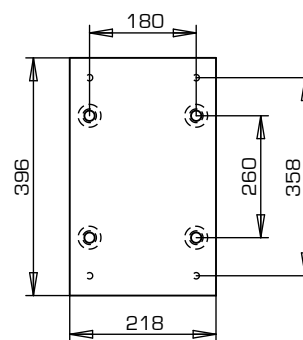

PF45

S	Material
27	1.1730

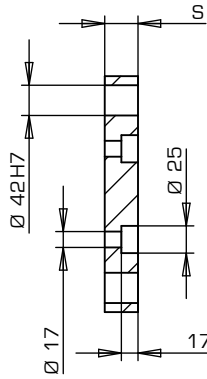
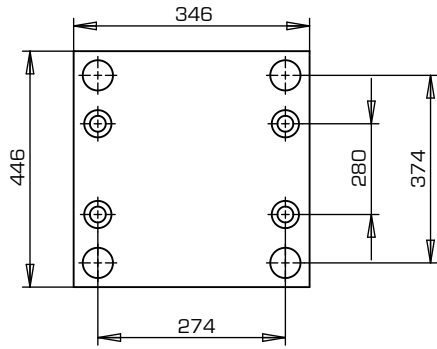

PD15

S	Material
27	1.1730

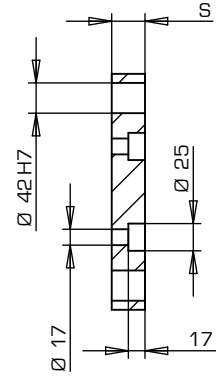
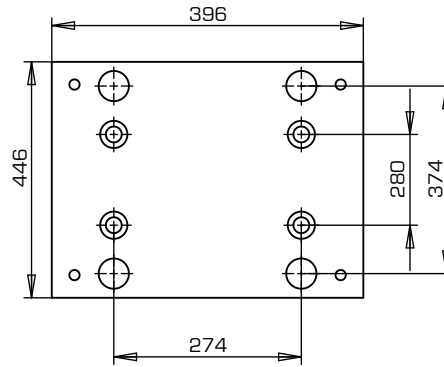

S50

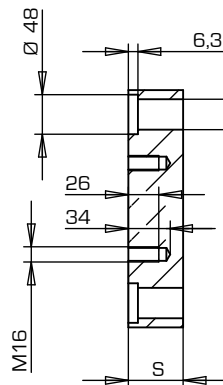
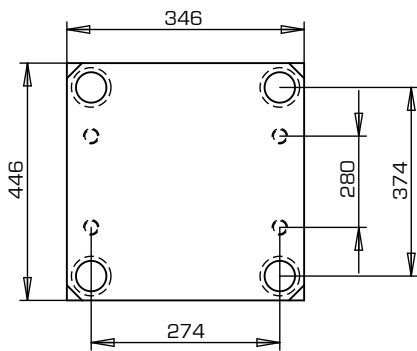

S	Material
36	1.1730 1.2311
46	
56	
66	
76	
86	
96	
116	

S60

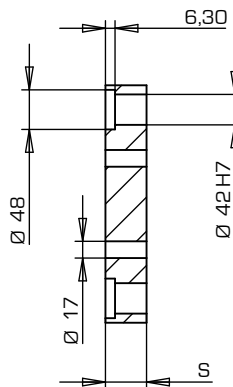
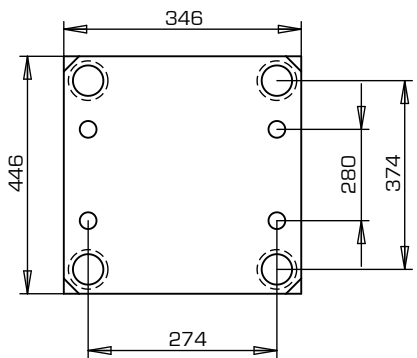

S	Material
36	1.1730 1.2311
46	
56	
66	
76	
86	
96	
116	

D70

S	Material
76	1.1730
96	
116	

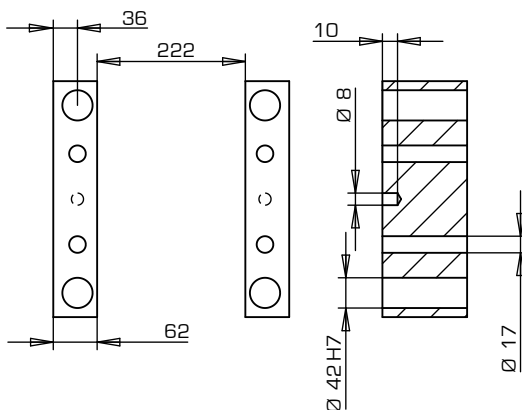

T80-T85/T90

S	Material
17+22	1.1730

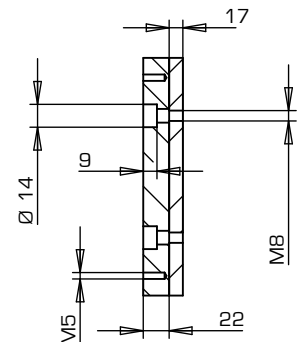
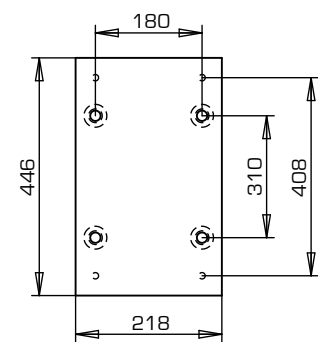

PF45

S	Material
27	1.1730

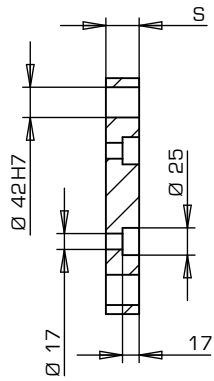
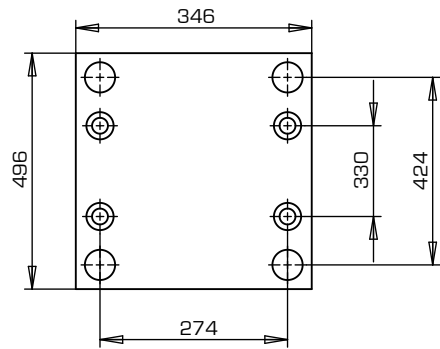

PD15

S	Material
27	1.1730

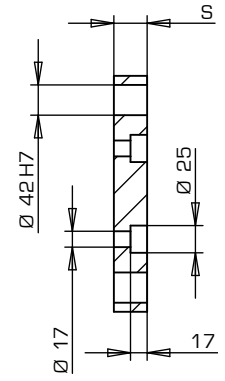
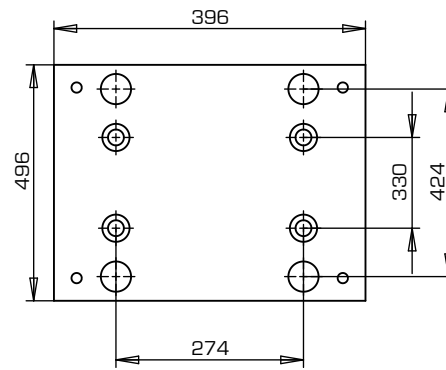

S50

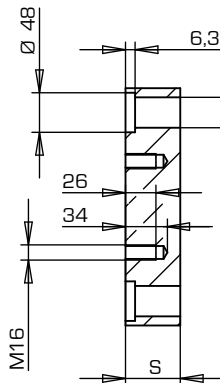
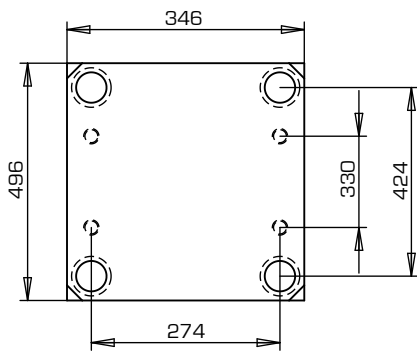

S	Material
36	1.1730 1.2311
46	
56	
66	
76	
86	
96	
116	

S60

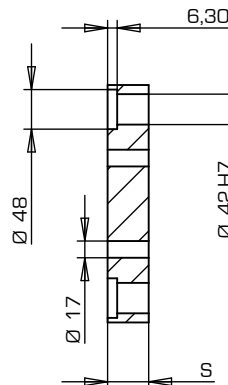
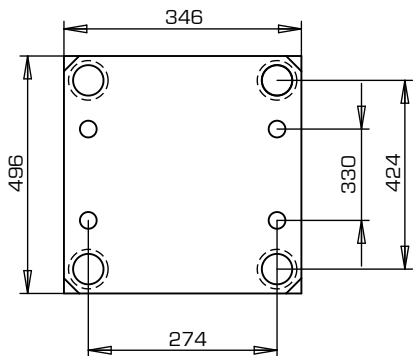

S	Material
36	1.1730 1.2311
46	
56	
66	
76	
86	
96	
116	

D70

S	Material
76	1.1730
96	
116	

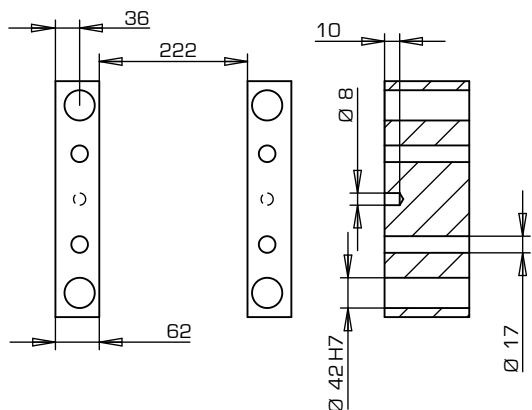

T80-T85/T90

S	Material
17+22	1.1730

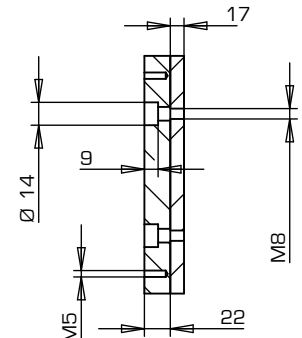
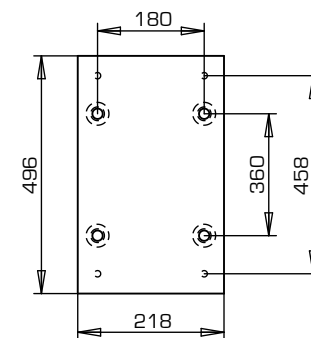

PF45

S	Material
36	1.1730

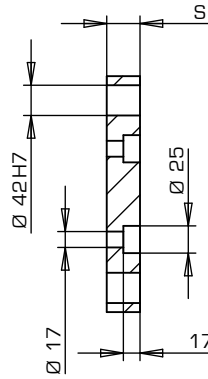
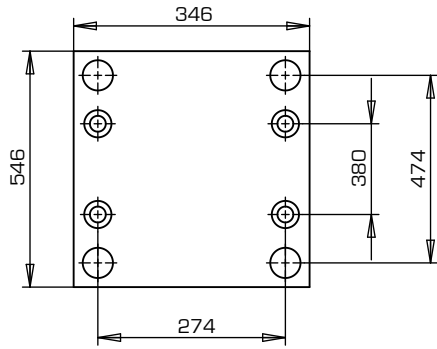

PD15

S	Material
36	1.1730

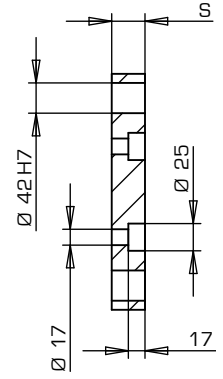
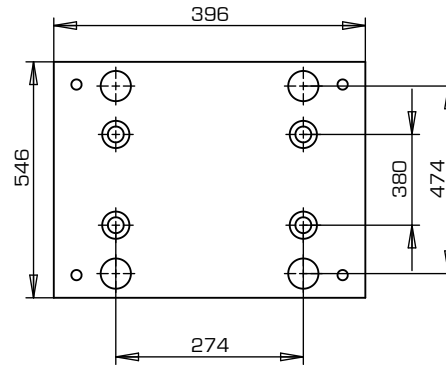

S50

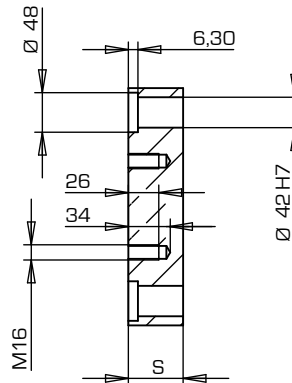
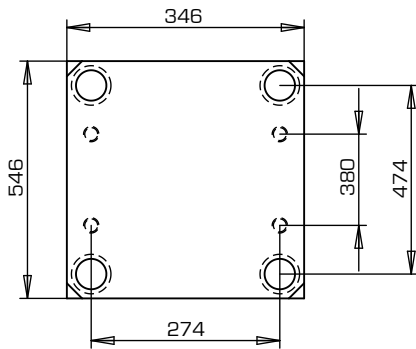

S	Material
36	1.1730 1.2311
46	
56	
66	
76	
86	
96	
116	

S60

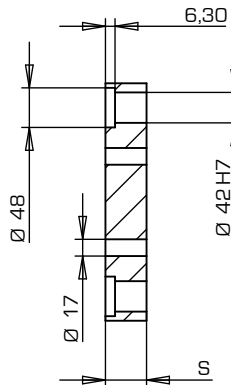
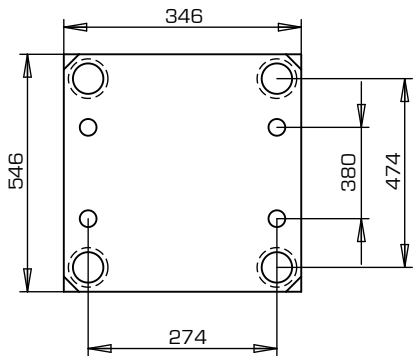

S	Material
36	1.1730 1.2311
46	
56	
66	
76	
86	
96	
116	

D70

S	Material
76	1.1730
96	
116	

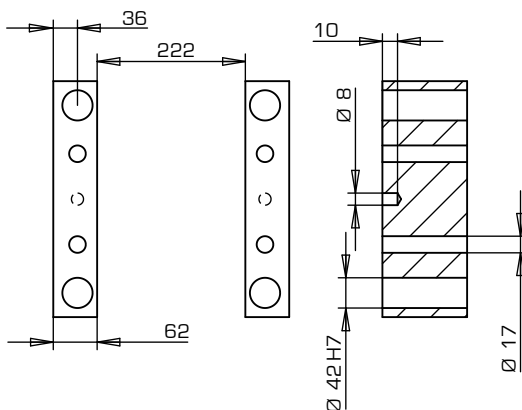

T80-T85/T90

S	Material
22+27	1.1730

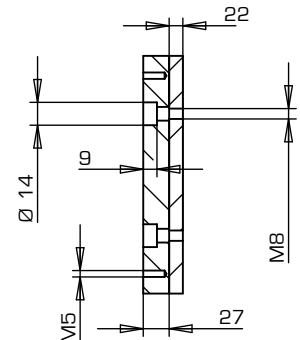
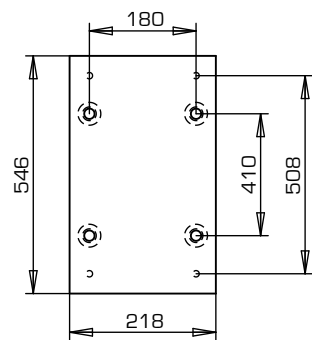

PF45

S	Material
36	1.1730

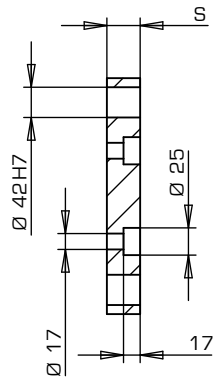
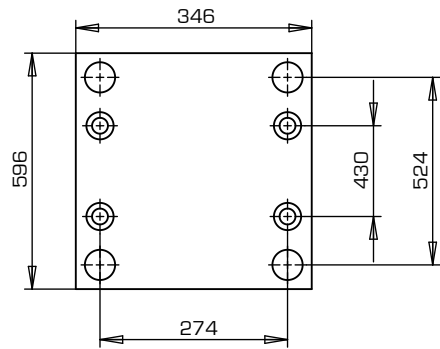

PD15

S	Material
36	1.1730

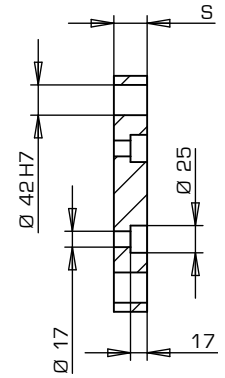
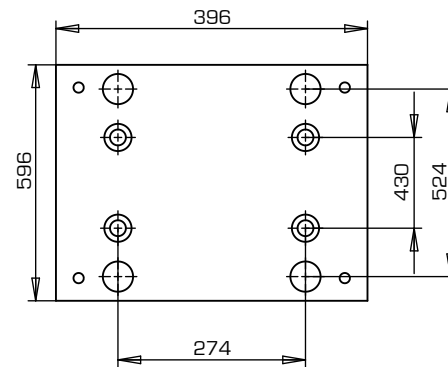

S50

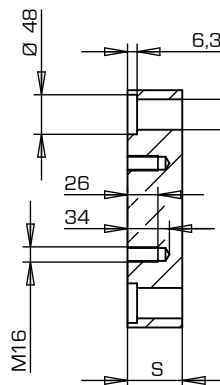
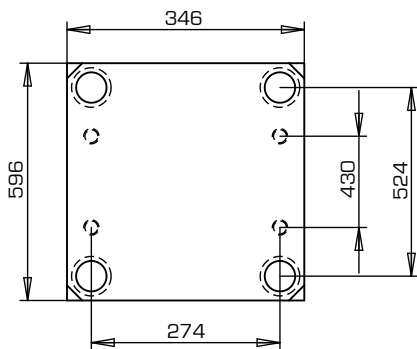

S	Material
36	1.1730 1.2311
46	
56	
66	
76	
86	
96	
116	

S60

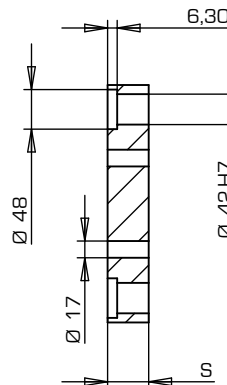
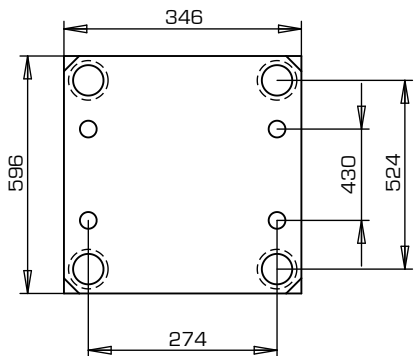

S	Material
36	1.1730 1.2311
46	
56	
66	
76	
86	
96	
116	

D70

S	Material
76	1.1730
96	
116	

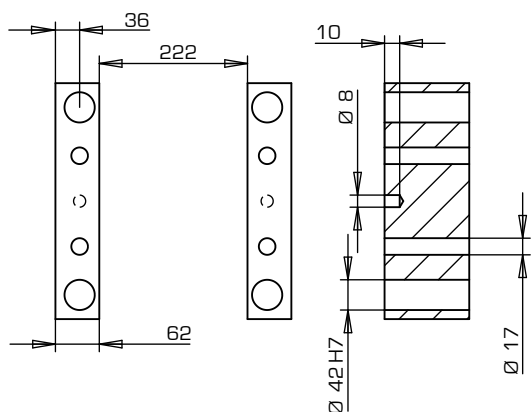

T80-T85/T90

S	Material
22+27	1.1730

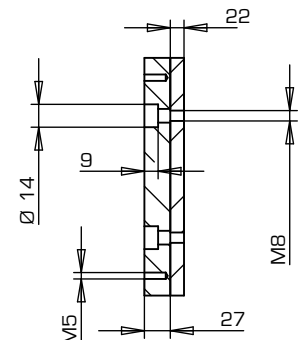
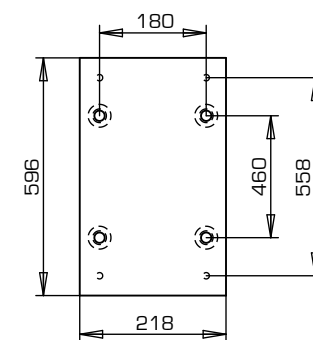

PF45

S	Material
36	1.1730

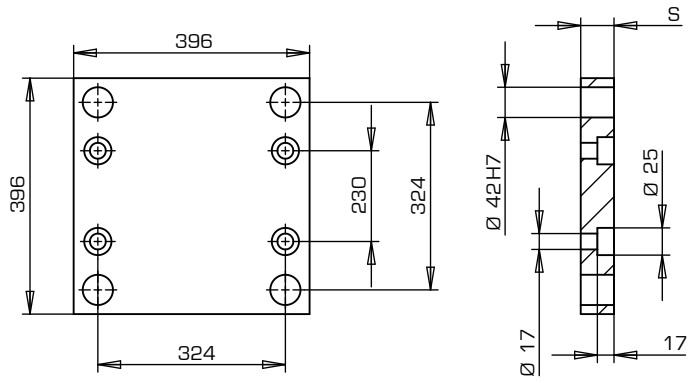

PD15

S	Material
36	1.1730

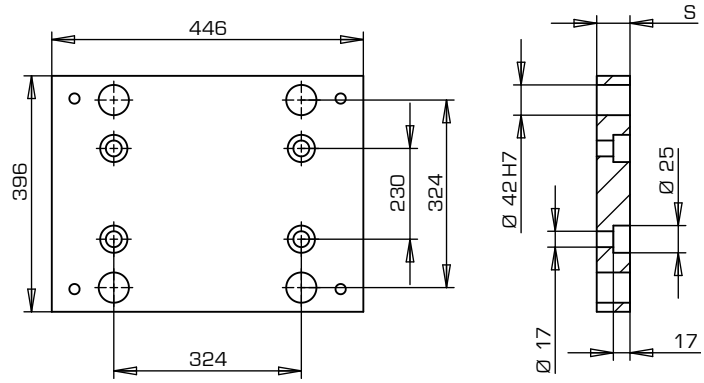

S50

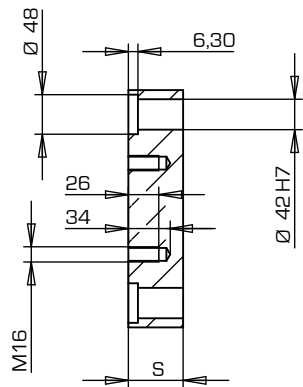
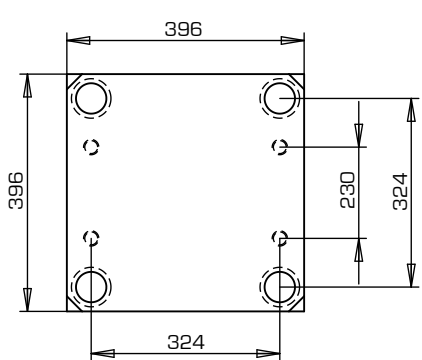

S	Material
36	
46	
56	
66	
76	1.1730 1.2311
86	
96	
116	
136	

S60

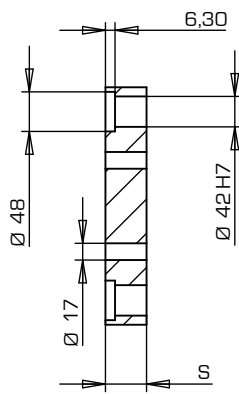
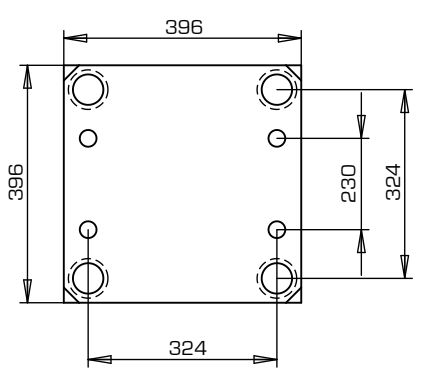

S	Material
36	
46	
56	
66	
76	1.1730 1.2311
86	
96	
116	
136	

D70

S	Material
76	
96	1.1730
116	
136	

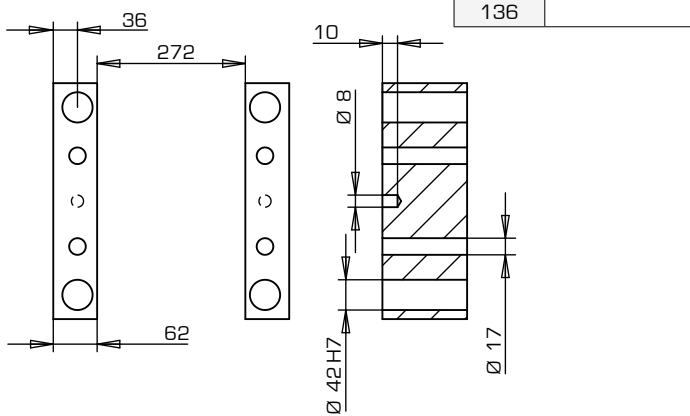

T80-T85/T90

S	Material
17+22	1.1730

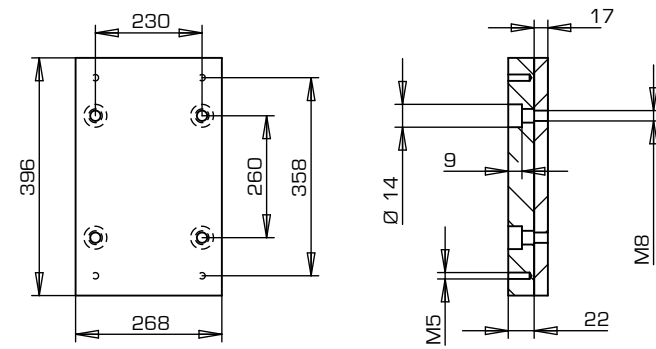

PF45

S	Material
36	1.1730

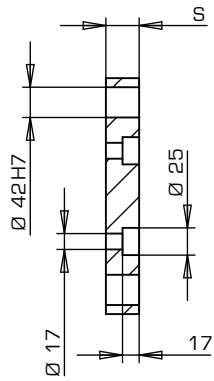
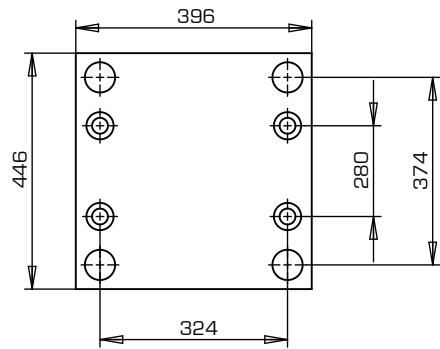

PD15

S	Material
36	1.1730

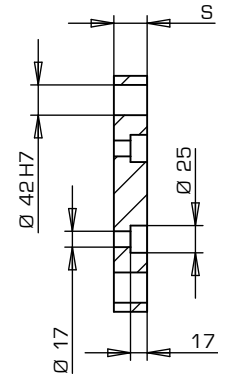
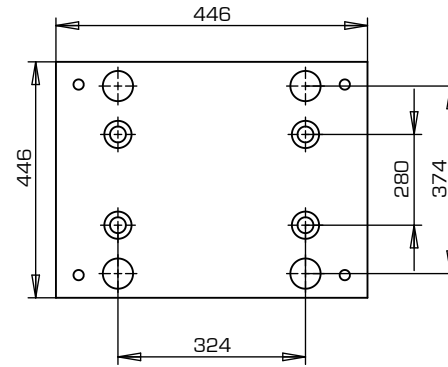

S50

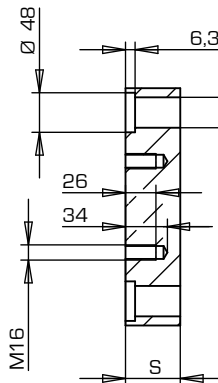
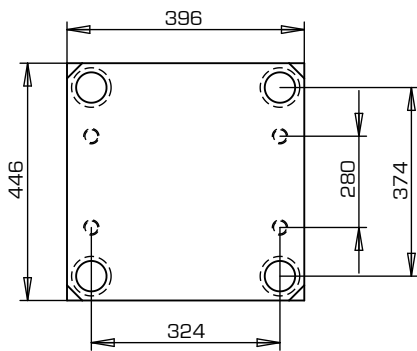

S	Material
36	1.1730 1.2311
46	
56	
66	
76	
86	
96	
116	
136	

S60

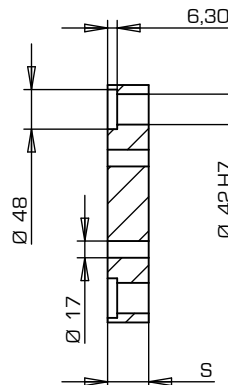
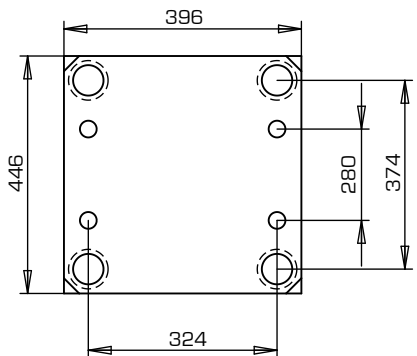

S	Material
36	1.1730 1.2311
46	
56	
66	
76	
86	
96	
116	
136	

D70

S	Material
76	1.1730
96	
116	
136	

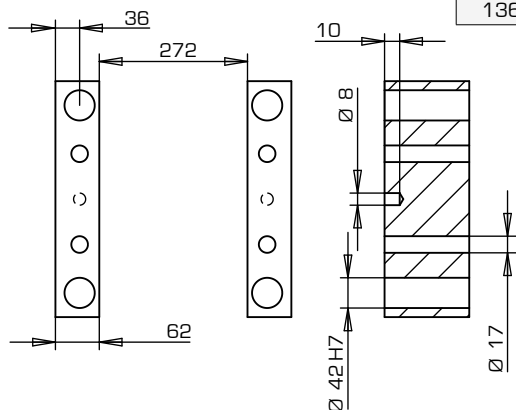

T80-T85/T90

S	Material
17+27	1.1730

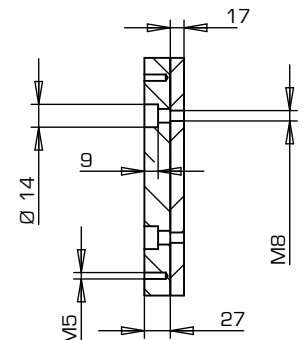
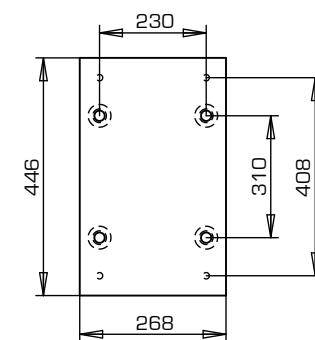

PF45

S	Material
36	1.1730

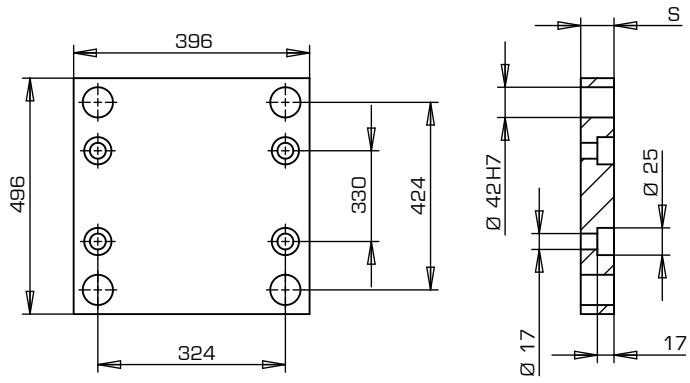

PD15

S	Material
36	1.1730

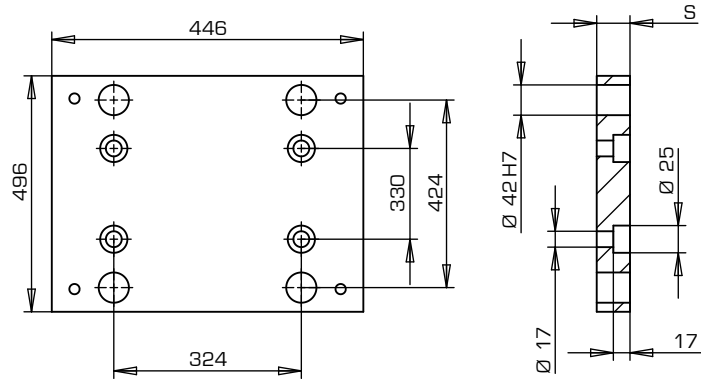

S50

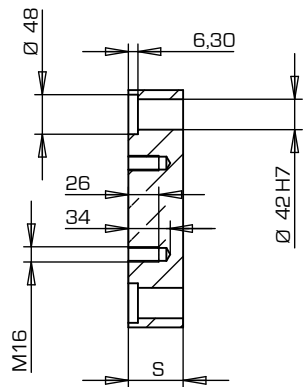
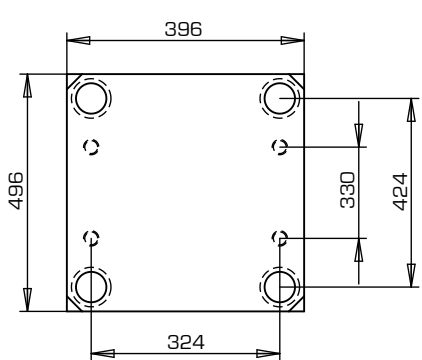

S	Material
36	
46	
56	
66	
76	1.1730
86	1.2311
96	
116	
136	

S60

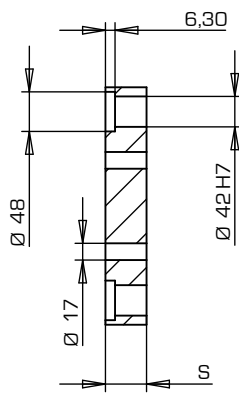
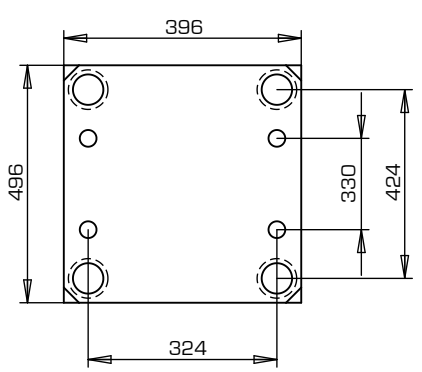

S	Material
36	
46	
56	
66	
76	1.1730
86	1.2311
96	
116	
136	

D70

S	Material
76	
96	
116	1.1730
136	

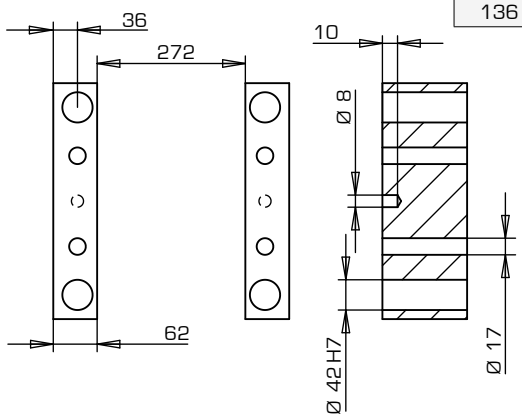

T80-T85/T90

S	Material
22+27	1.1730

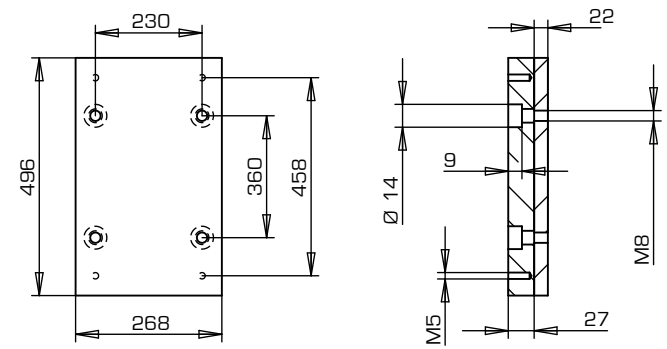

PF45

S	Material
36	1.1730

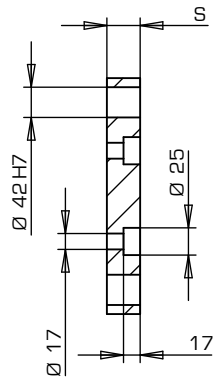
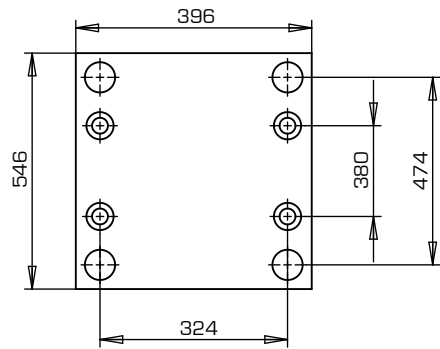

PD15

S	Material
36	1.1730

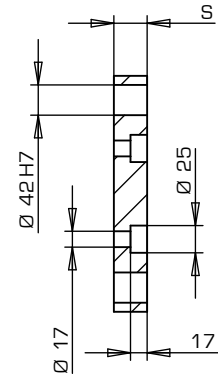
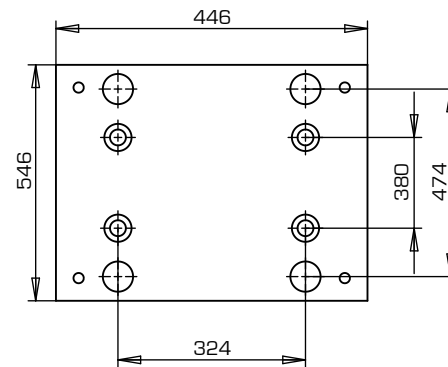

S50

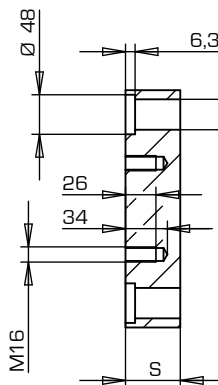
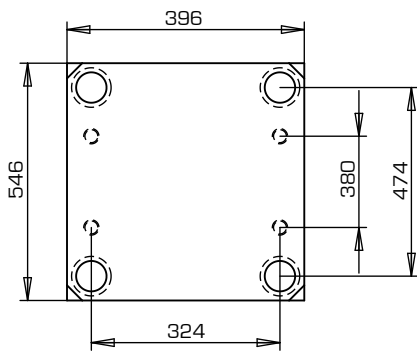

S	Material
36	1.1730 1.2311
46	
56	
66	
76	
86	
96	
116	
136	

S60

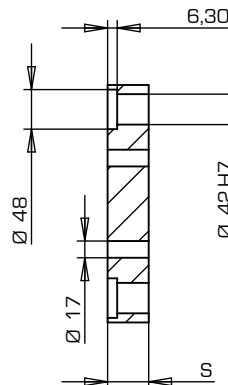
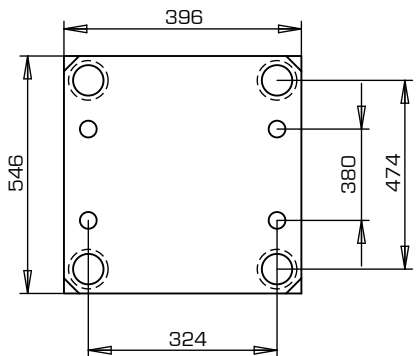

S	Material
36	1.1730 1.2311
46	
56	
66	
76	
86	
96	
116	
136	

D70

S	Material
76	1.1730
96	
116	
136	

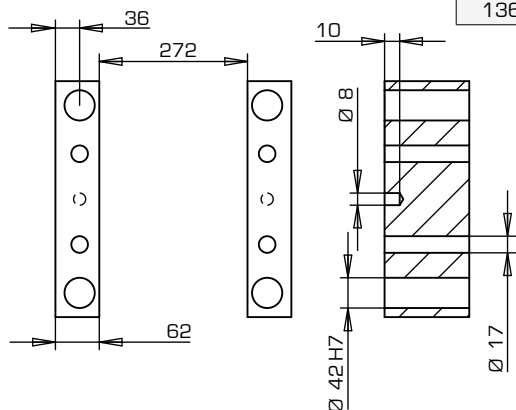

T80-T85/T90

S	Material
22+27	1.1730

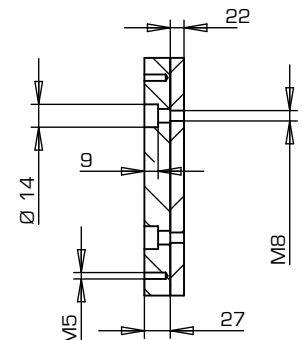
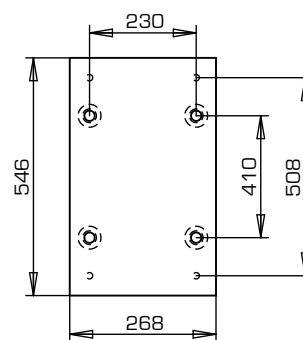

PF45

S	Material
36	1.1730

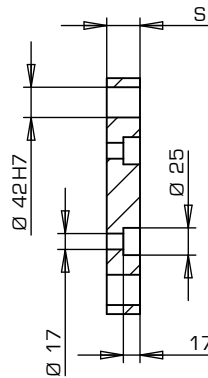
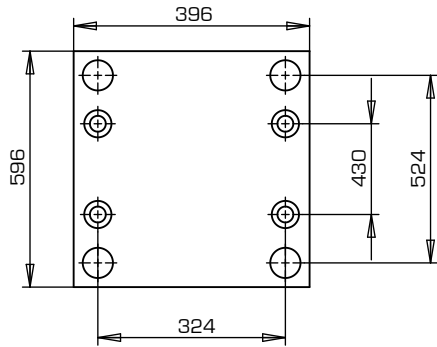

PD15

S	Material
36	1.1730

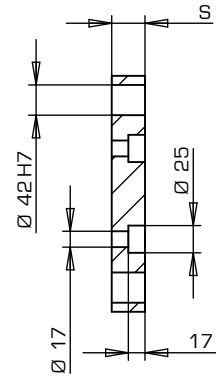
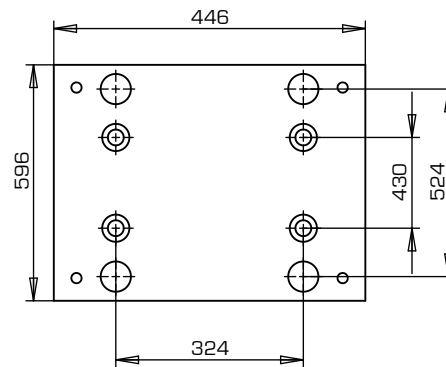

S50

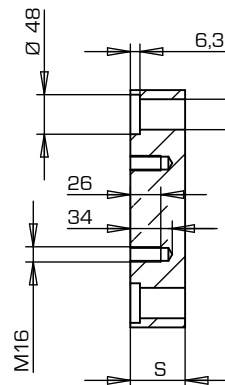
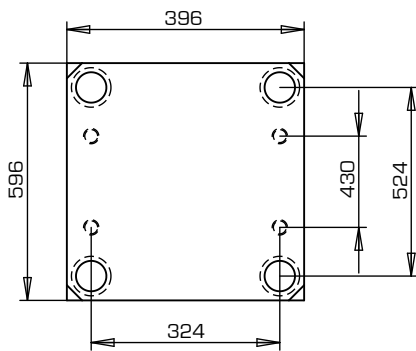

S	Material
36	
46	
56	
66	
76	1.1730 1.2311
86	
96	
116	
136	

S60

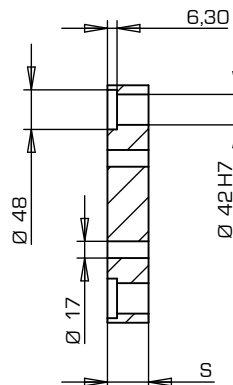
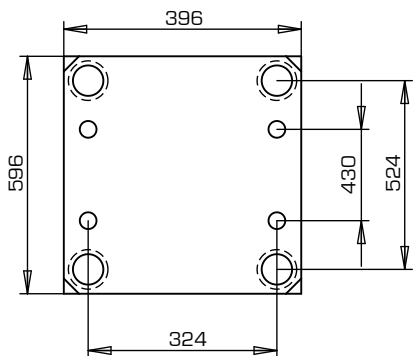

S	Material
36	
46	
56	
66	
76	1.1730 1.2311
86	
96	
116	
136	

D70

S	Material
76	
96	1.1730
116	
136	

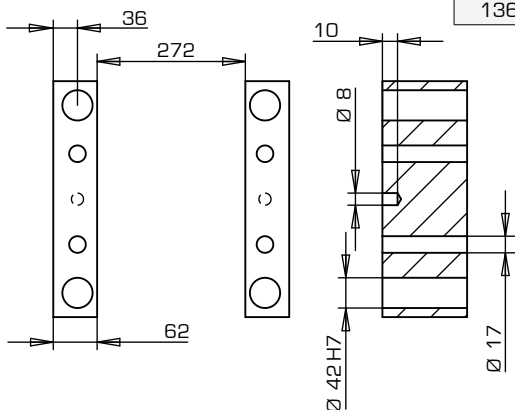

T80-T85/T90

S	Material
22+27	1.1730

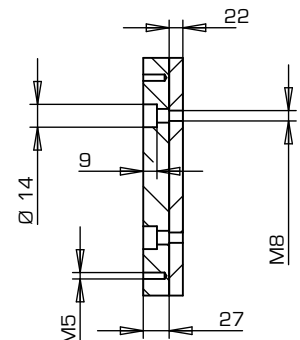
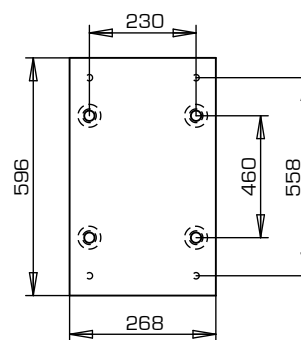

PF45

S	Material
36	1.1730

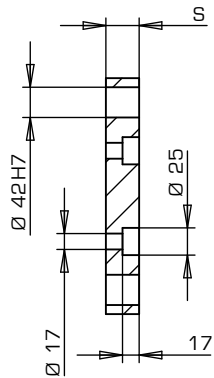
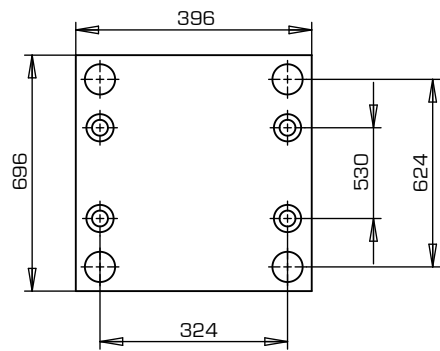

PD15

S	Material
36	1.1730

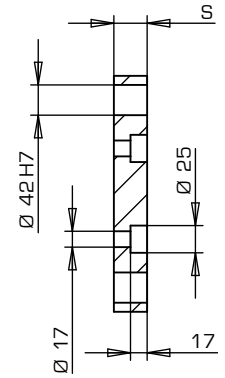
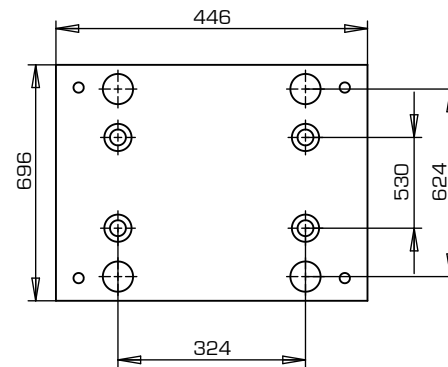

S50

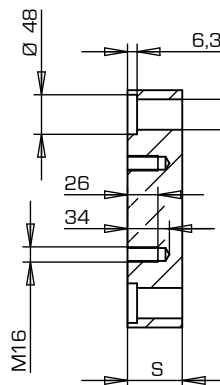
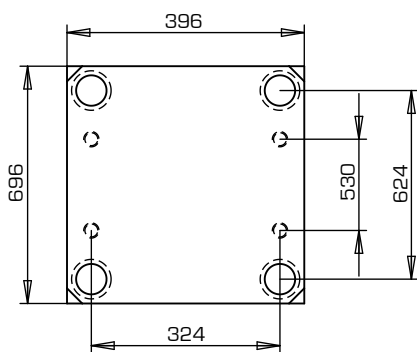

S	Material
36	1.1730 1.2311
46	
56	
66	
76	
86	
96	
116	
136	

S60

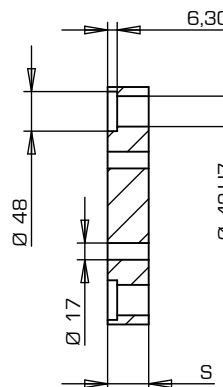
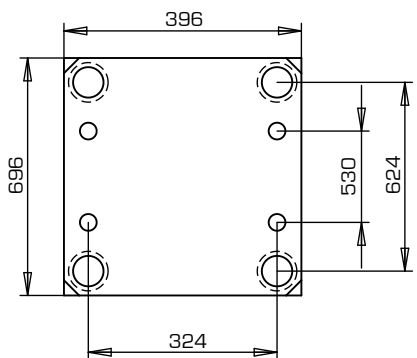

S	Material
36	1.1730 1.2311
46	
56	
66	
76	
86	
96	
116	
136	

D70

S	Material
76	1.1730
96	
116	
136	

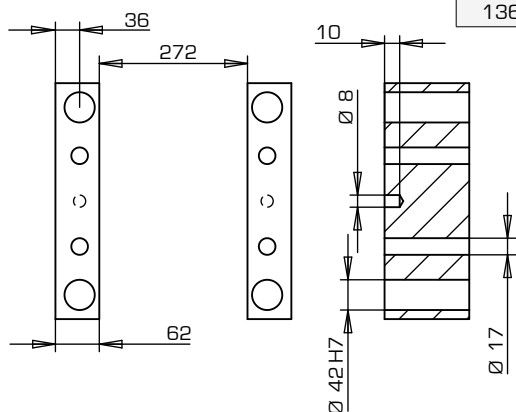

T80-T85/T90

S	Material
27+36	1.1730

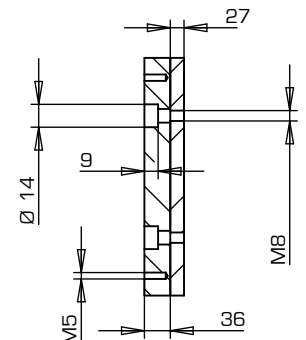
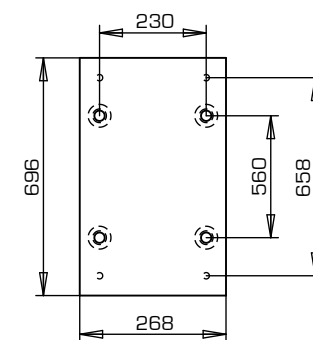

PF45

S	Material
36	1.1730

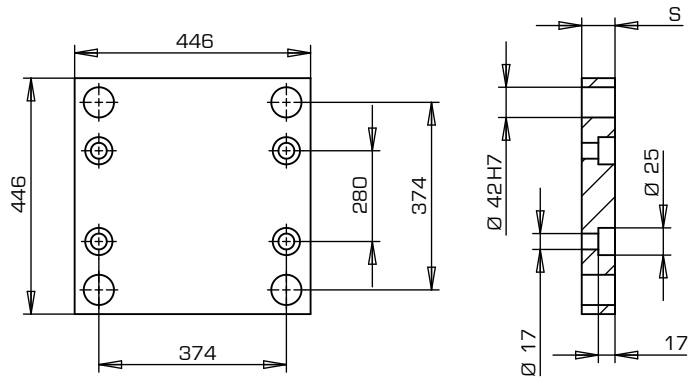

PD15

S	Material
36	1.1730

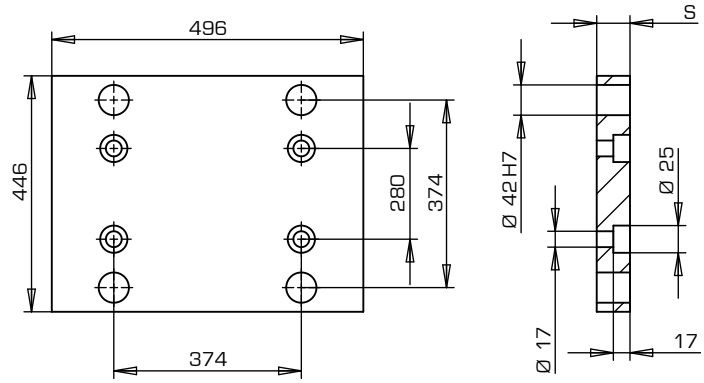

S50

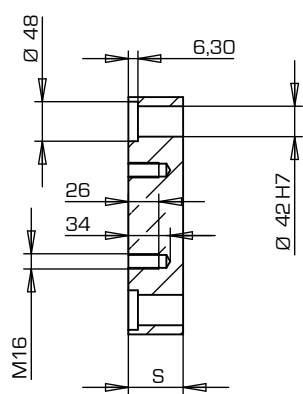
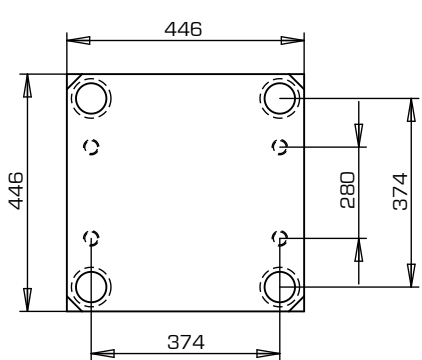

S	Material
46	1.1730 1.2311
56	
66	
76	
86	
96	
116	
136	
156	

S60

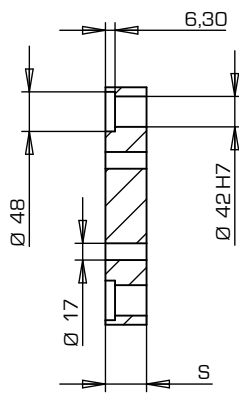
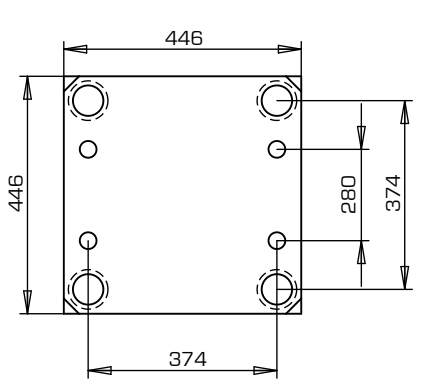

S	Material
46	1.1730 1.2311
56	
66	
76	
86	
96	
116	
136	
156	

D70

S	Material
76	1.1730
96	
116	
136	

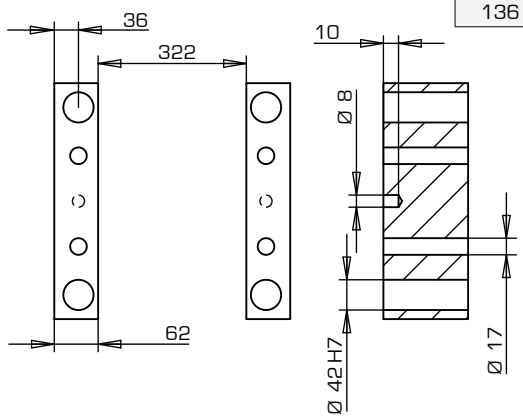

T80-T85/T90

S	Material
22+27	1.1730

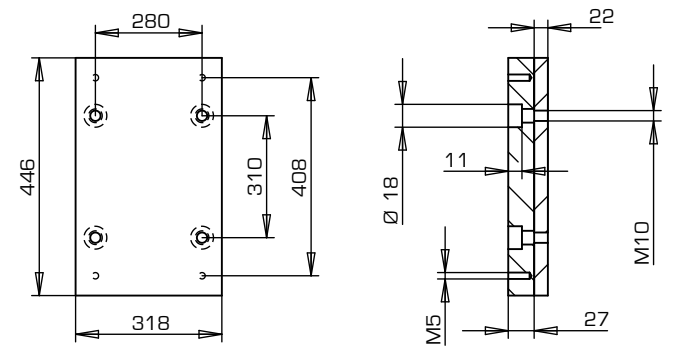

PF45

S	Material
36	1.1730

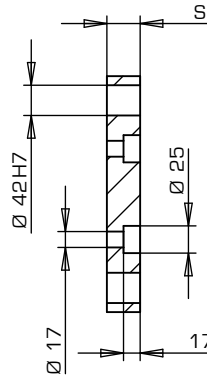
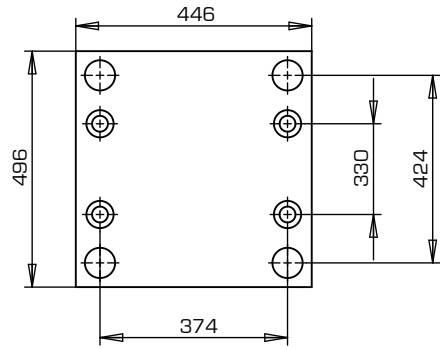

PD15

S	Material
36	1.1730

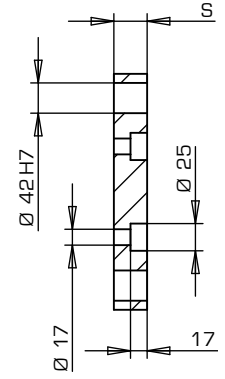
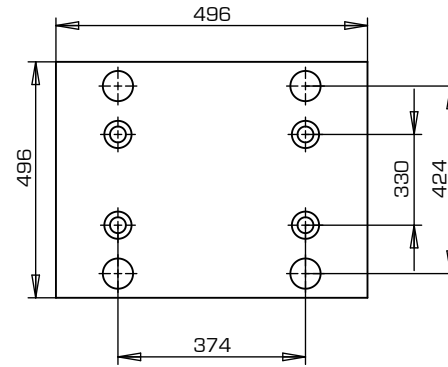

S50

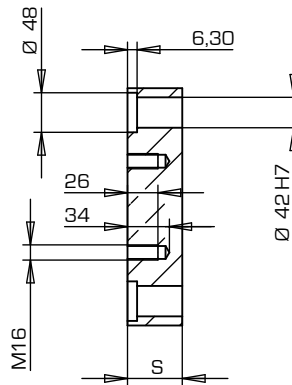
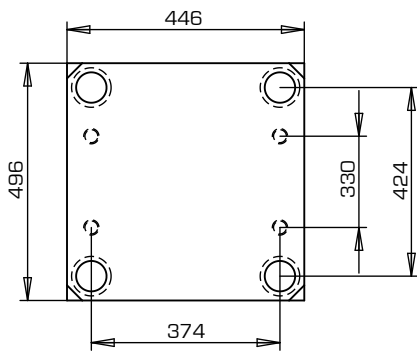

S	Material
46	1.1730 1.2311
56	
66	
76	
86	
96	
116	
136	
156	

S60

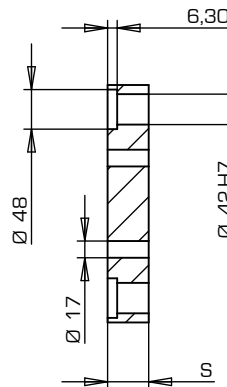
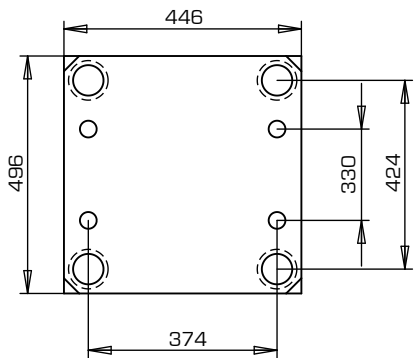

S	Material
46	1.1730 1.2311
56	
66	
76	
86	
96	
116	
136	
156	

D70

S	Material
76	1.1730
96	
116	
136	

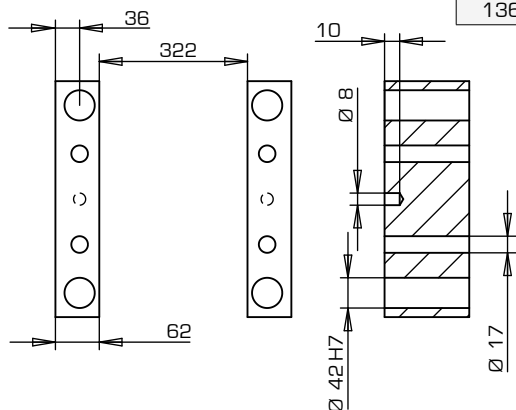

T80-T85/T90

S	Material
22+27	1.1730

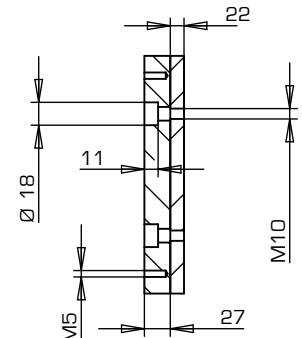
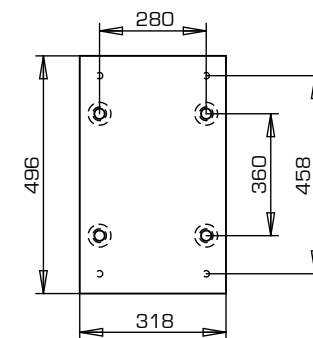

PF45

S	Material
36	1.1730

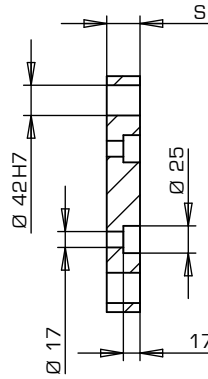
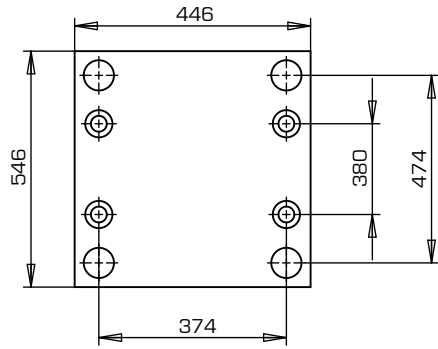

PD15

S	Material
36	1.1730

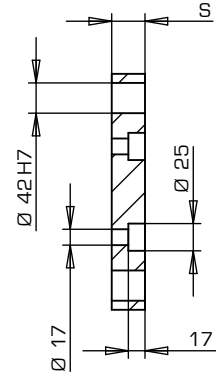
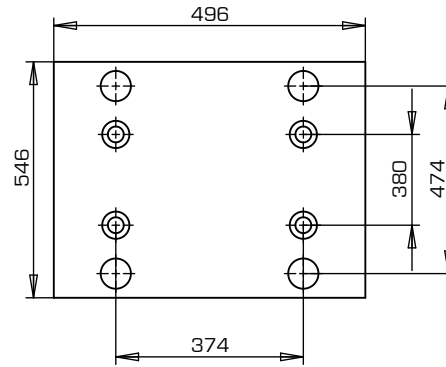

S50

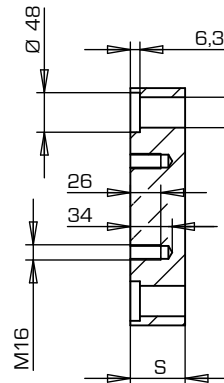
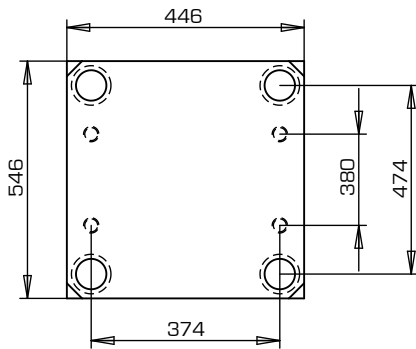

S	Material
46	
56	
66	
76	
86	1.1730 1.2311
96	
116	
136	
156	

S60

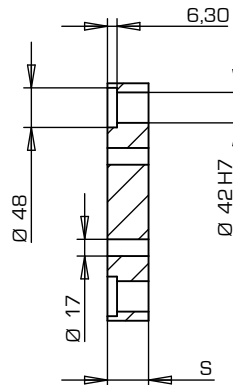
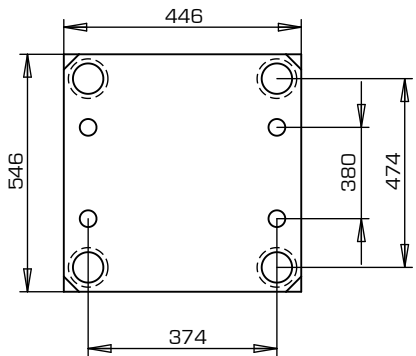

S	Material
46	
56	
66	
76	
86	1.1730 1.2311
96	
116	
136	
156	

D70

S	Material
76	
96	1.1730
116	
136	

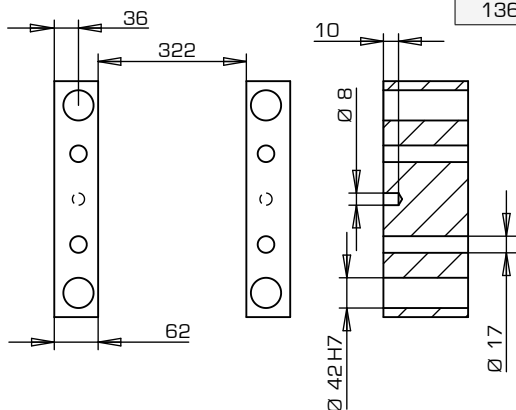

T80-T85/T90

S	Material
22+27	1.1730

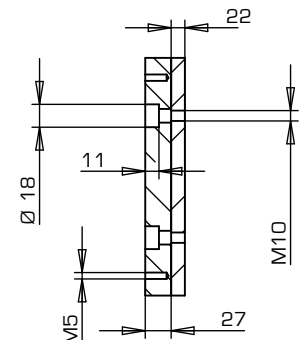
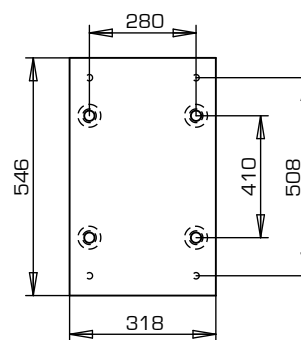

PF45

S	Material
36	1.1730

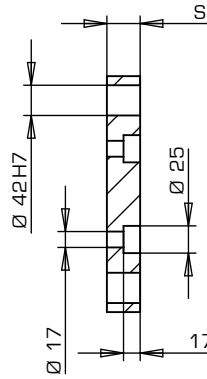
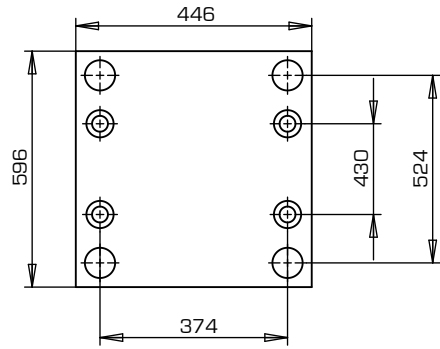

PD15

S	Material
36	1.1730

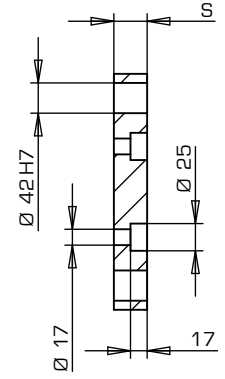
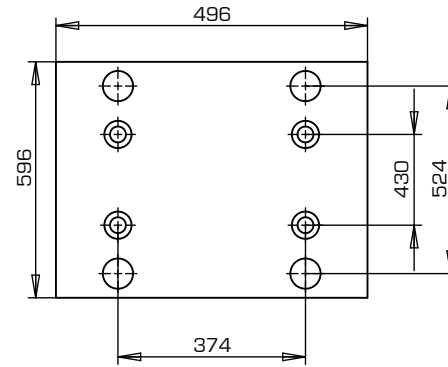

S50

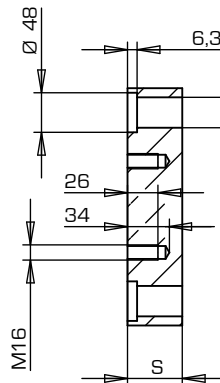
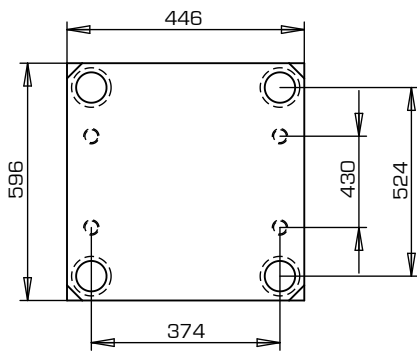

S	Material
46	1.1730 1.2311
56	
66	
76	
86	
96	
116	
136	
156	

S60

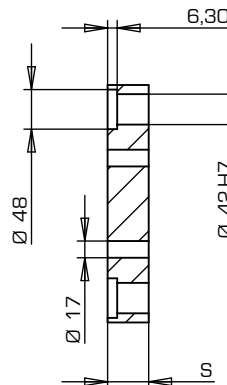
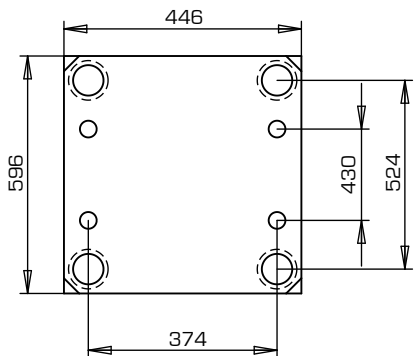

S	Material
46	1.1730 1.2311
56	
66	
76	
86	
96	
116	
136	
156	

D70

S	Material
76	1.1730
96	
116	
136	

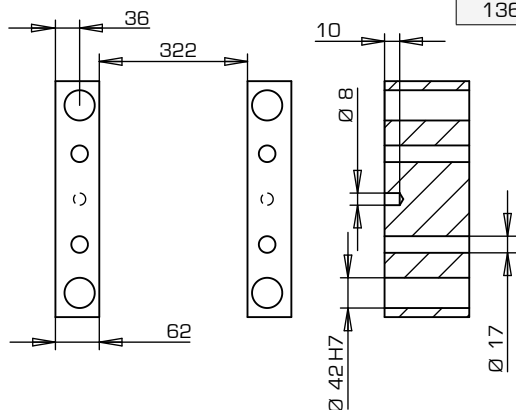

T80-T85/T90

S	Material
22+27	1.1730

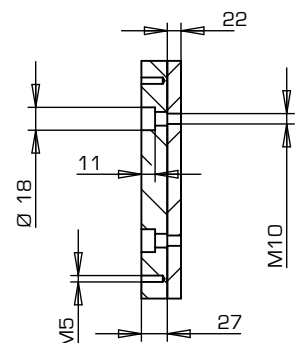
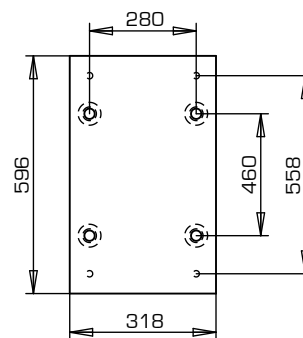

PF45

S	Material
46	1.1730

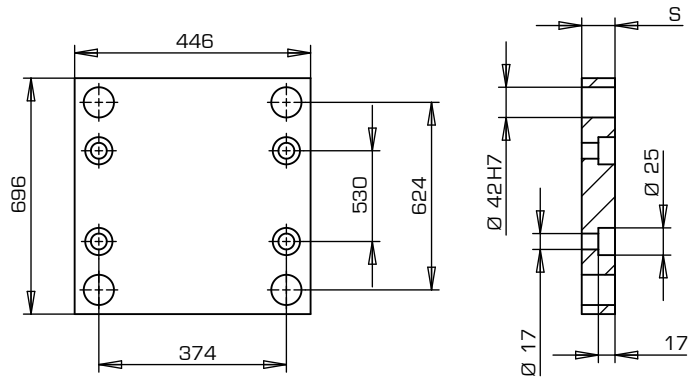

PD15

S	Material
46	1.1730

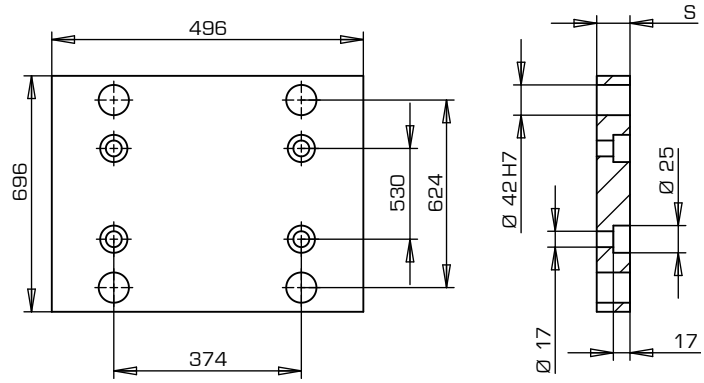

S50

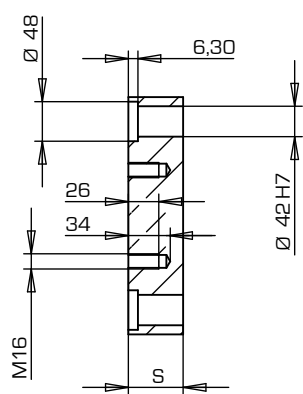
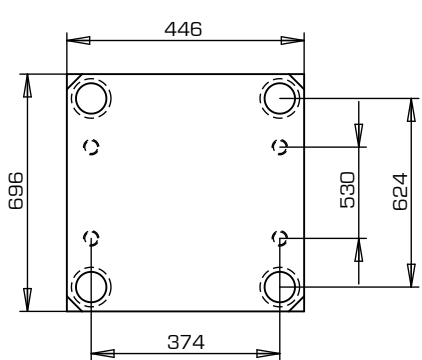

S	Material
46	
56	
66	
76	
86	1.1730 1.2311
96	
116	
136	
156	

S60

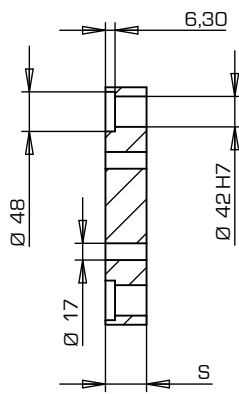
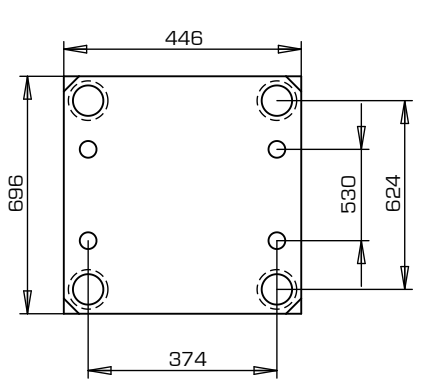

S	Material
46	
56	
66	
76	
86	1.1730 1.2311
96	
116	
136	
156	

D70

S	Material
76	
96	1.1730
116	
136	

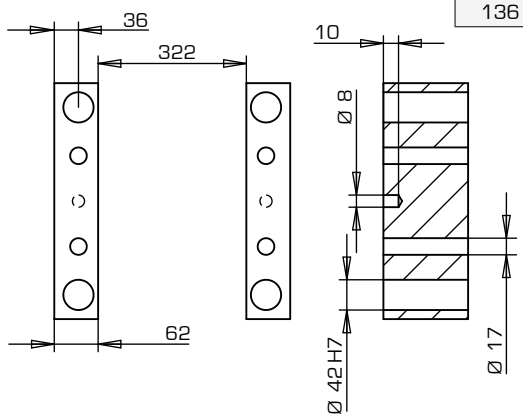

T80-T85/T90

S	Material
27+36	1.1730

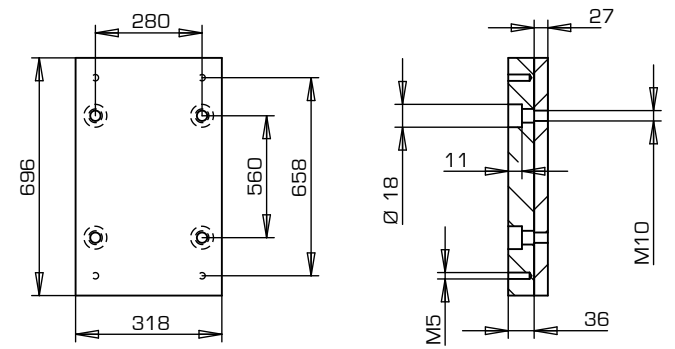

PF45

S	Material
46	1.1730

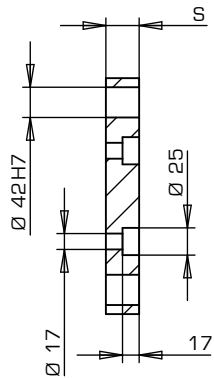
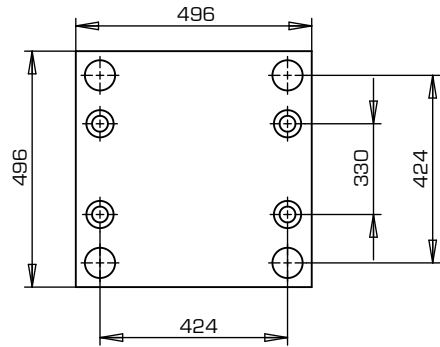

PD15

S	Material
46	1.1730

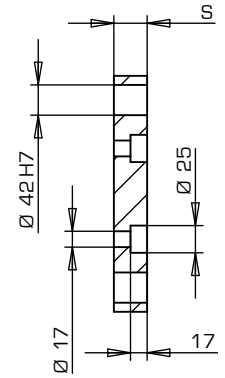
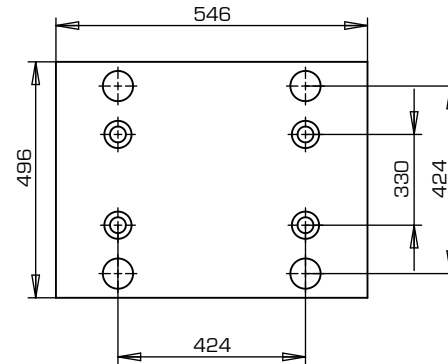

S50

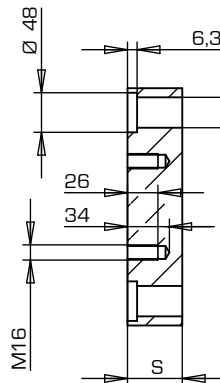
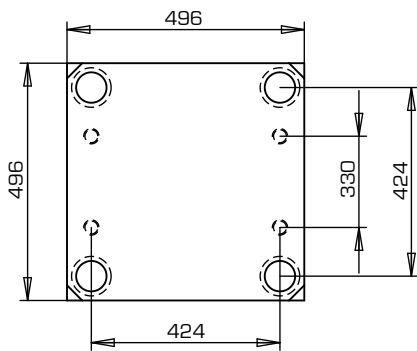

S	Material
46	1.1730 1.2311
56	
66	
76	
86	
96	
116	
136	
156	

S60

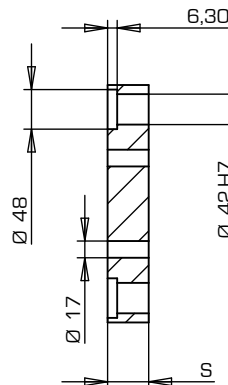
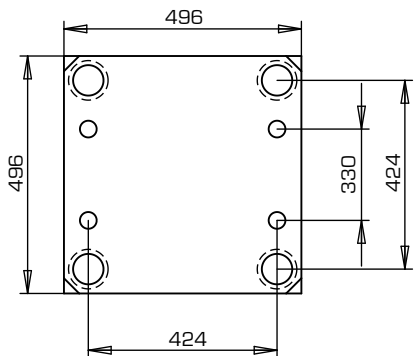

S	Material
46	1.1730 1.2311
56	
66	
76	
86	
96	
116	
136	
156	

D70

S	Material
76	1.1730
96	
116	
136	

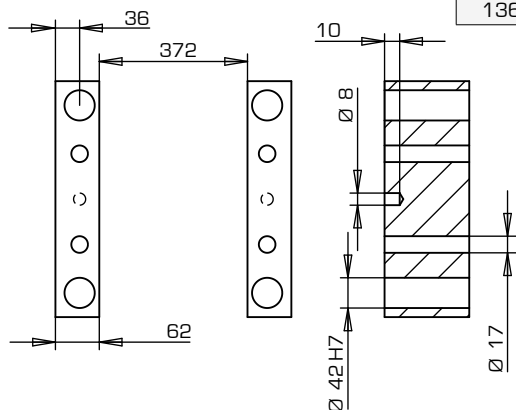

T80-T85/T90

S	Material
22+27	1.1730

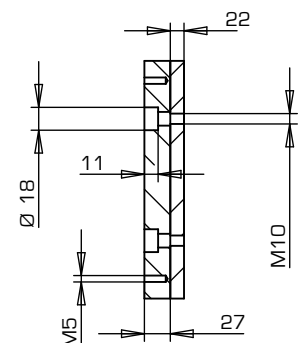
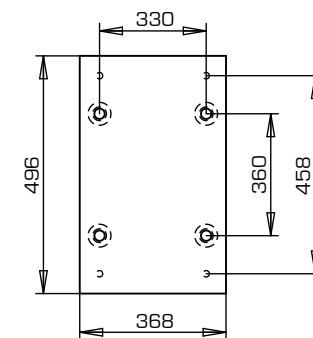

PF45

S	Material
46	1.1730

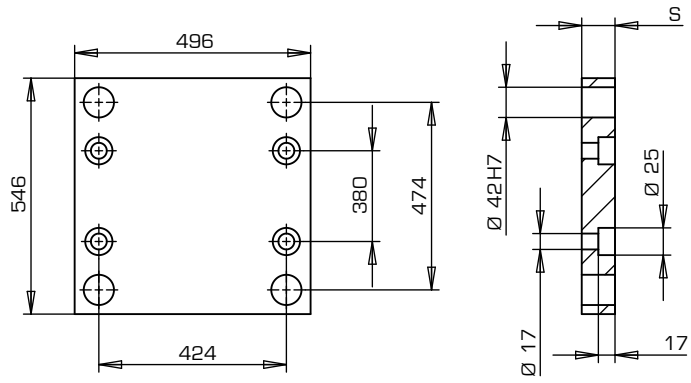

PD15

S	Material
46	1.1730

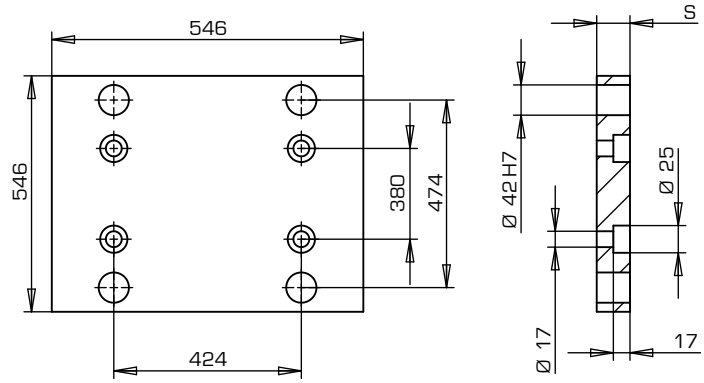

S50

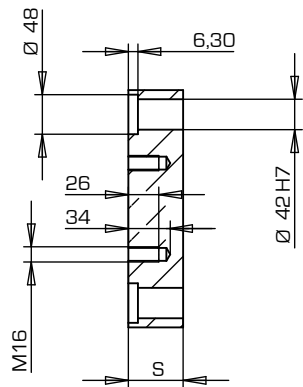
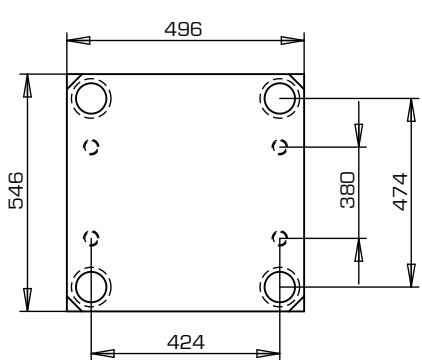

S	Material
46	
56	
66	
76	
86	1.1730 1.2311
96	
116	
136	
156	

S60

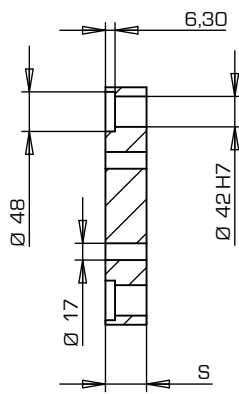
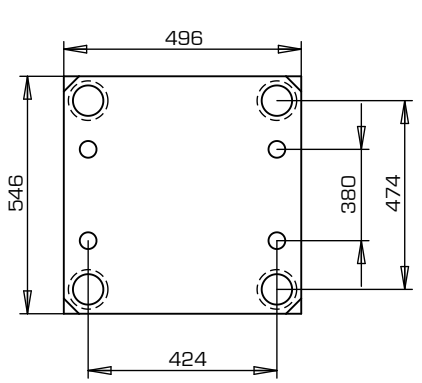

S	Material
46	
56	
66	
76	
86	1.1730 1.2311
96	
116	
136	
156	

D70

S	Material
76	
96	1.1730
116	
136	

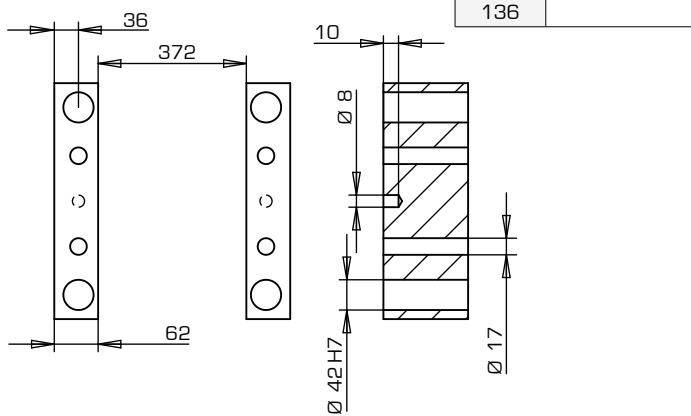

T80-T85/T90

S	Material
22+27	1.1730

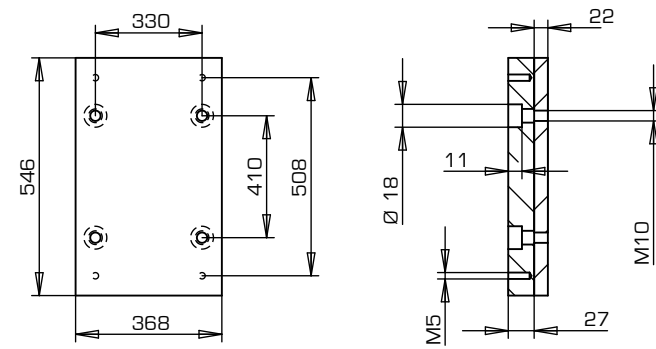

PF45

S	Material
46	1.1730

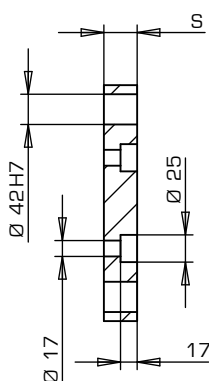
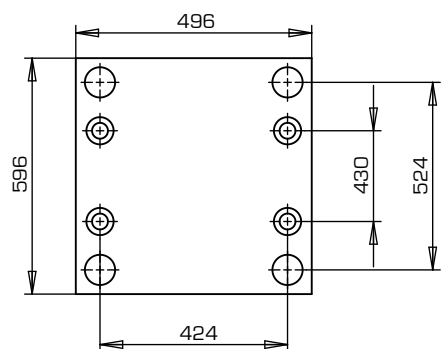

PD15

S	Material
46	1.1730

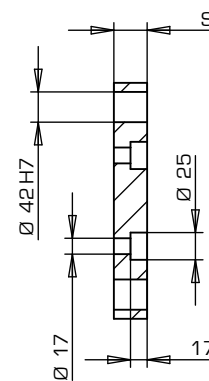
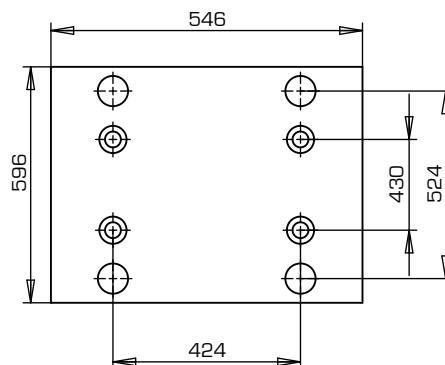

S50

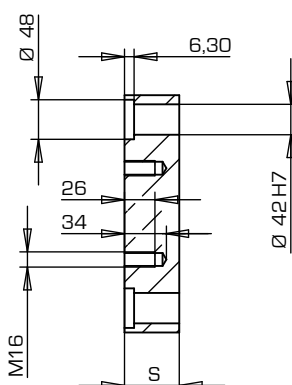
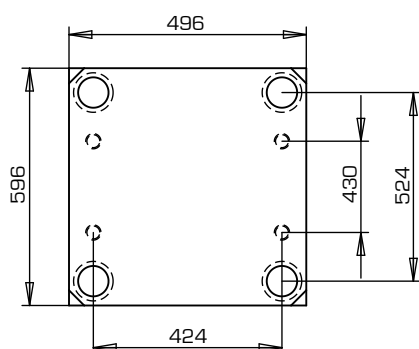

S	Material
46	1.1730 1.2311
56	
66	
76	
86	
96	
116	
136	
156	

S60

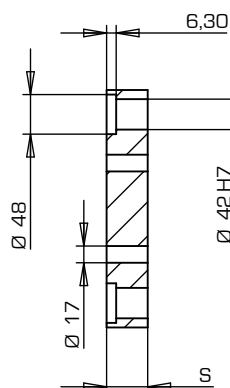
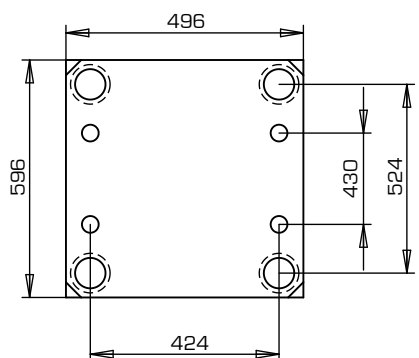

S	Material
46	1.1730 1.2311
56	
66	
76	
86	
96	
116	
136	
156	

D70

S	Material
76	1.1730
96	
116	
136	

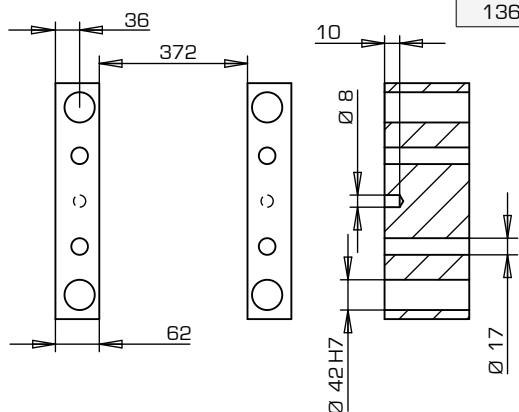

T80-T85/T90

S	Material
27+36	1.1730

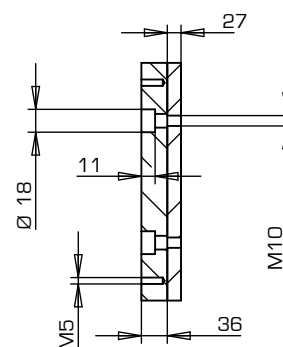
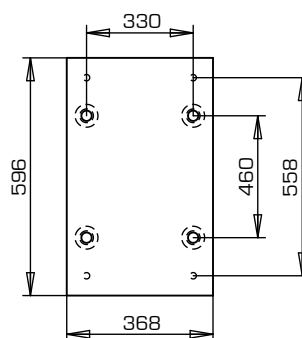

PF45

S	Material
46	1.1730

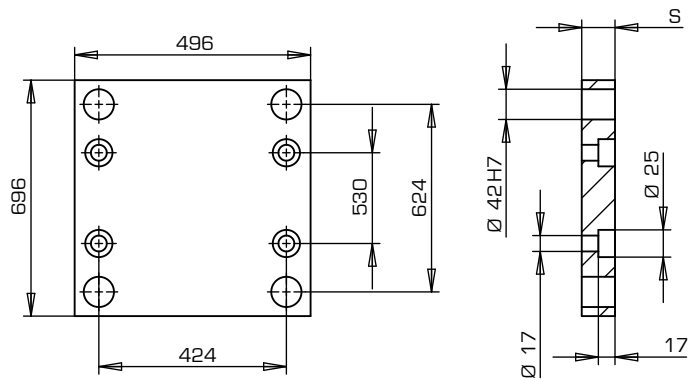

PD15

S	Material
46	1.1730

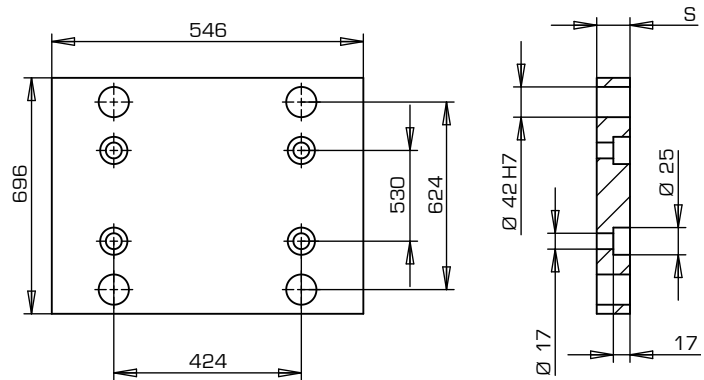

S50

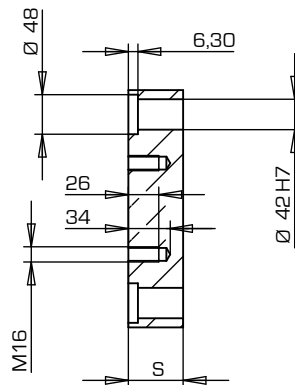
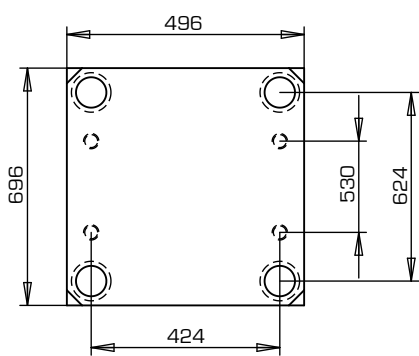

S	Material
46	
56	
66	
76	
86	1.1730 1.2311
96	
116	
136	
156	

S60

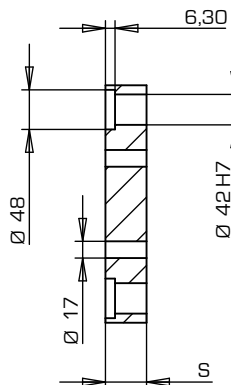
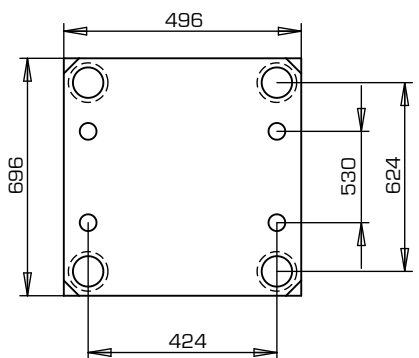

S	Material
46	
56	
66	
76	
86	1.1730 1.2311
96	
116	
136	
156	

D70

S	Material
76	
96	1.1730
116	
136	

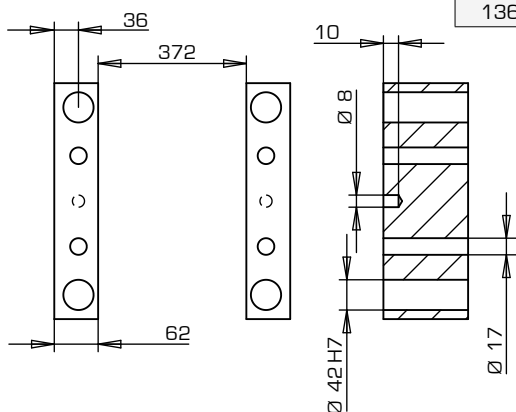

T80-T85/T90

S	Material
27+36	1.1730

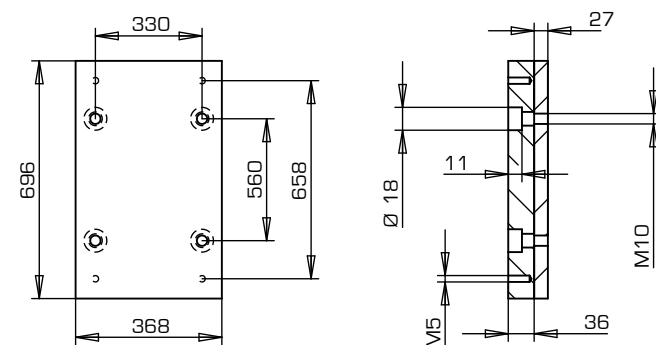

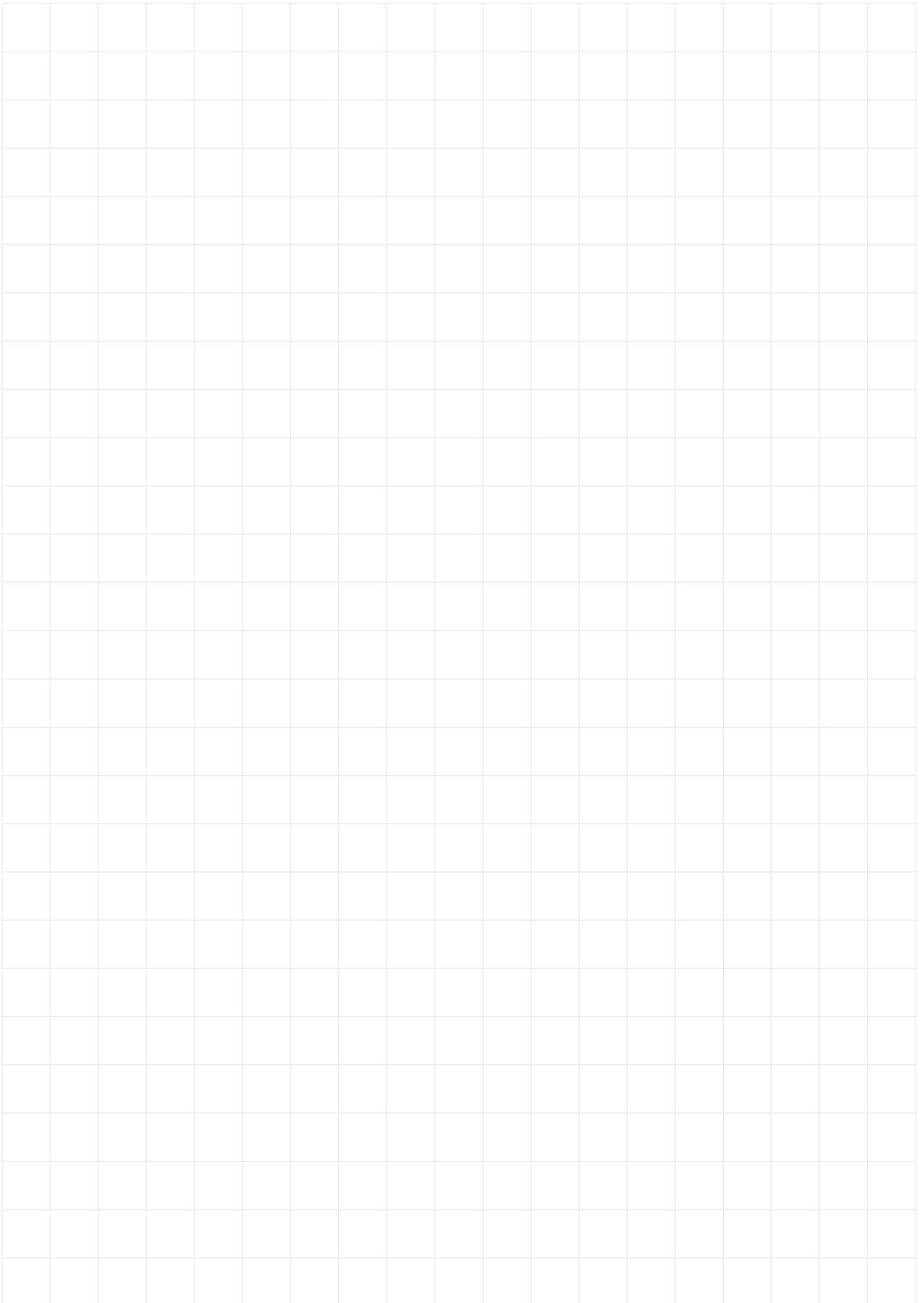

ELEMENTI DI GUIDA
GUIDING ITEMS



R0216 Colonna guida due diametri spallata con forzatura - R00 Two diameters guide pillar with centering collar for a tight fit - R00

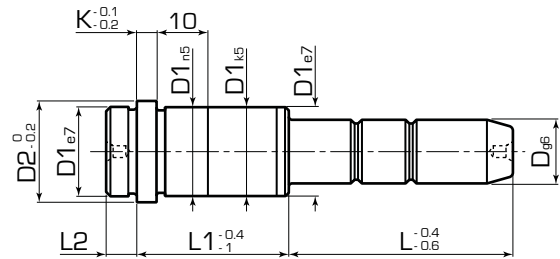

by **RANCO**

Descrizione:

Material: 1.7131 ≈60 HRC
Rivestimento: DLC su richiesta
Esempio di ordinativo: R0216-03-0001

Description:

Material: 1.7131 ≈60 HRC
Coating: DLC upon request
Example of purchasing order: R0216-03-0001

Codice Code	D	D1	D2	K	L2	L1	L																		
							25	35	55	75	95	115	135	155	195	215	235	245	275						
R0216-03	14	20	25	6	9	17		0001	0002	0003	0004														
R0216-03	14	20	25	6	9	22	0005	0006	0007	0008	0009	0010	0011												
R0216-03	14	20	25	6	9	27	0012	0013	0014	0015	0016	0017	0018	0019											
R0216-03	14	20	25	6	9	36	0020	0021	0022	0023	0024	0025	0026	0027											
R0216-03	14	20	25	6	9	46		0028	0029	0030	0031	0032	0033												
R0216-03	14	20	25	6	9	56		0034	0035	0036	0037	0038	0039												
R0216-03	14	20	25	6	9	66		0040	0041	0042	0043	0044													
R0216-03	14	20	25	6	9	76			0045	0046	0047														
R0216-03	14	20	25	6	9	86			0048	0049	0050														
R0216-03	14	20	25	6	9	96			0051	0052	0053														
R0216-03	15	20	25	6	9	17		0054	0055	0056	0057														
R0216-03	15	20	25	6	9	22	0058	0059	0060	0061	0062	0063	0064												
R0216-03	15	20	25	6	9	27	0065	0066	0067	0068	0069	0070	0071	0072											
R0216-03	15	20	25	6	9	36	0073	0074	0075	0076	0077	0078	0079	0080											
R0216-03	15	20	25	6	9	46		0081	0082	0083	0084	0085	0086												
R0216-03	15	20	25	6	9	56		0087	0088	0089	0090	0091	0092												
R0216-03	15	20	25	6	9	66		0093	0094	0095	0096	0097													
R0216-03	15	20	25	6	9	76			0098	0099	0100														
R0216-03	15	20	25	6	9	86			0101	0102	0103														
R0216-03	15	20	25	6	9	96			0104	0105	0106														
R0216-03	18	26	31	6	9	17		0107	0108	0109	0110	0111													
R0216-03	18	26	31	6	9	22		0112	0113	0114	0115	0116	0117												
R0216-03	18	26	31	6	9	27		0118	0119	0120	0121	0122	0123	0124	0125			0126							
R0216-03	18	26	31	6	9	36		0127	0128	0129	0130	0131	0132	0133	0134			0135							
R0216-03	18	26	31	6	9	46		0136	0137	0138	0139	0140	0141	0142	0143			0144							
R0216-03	18	26	31	6	9	56		0145	0146	0147	0148	0149	0150	0151	0152										
R0216-03	18	26	31	6	9	66		0153	0154	0155	0156	0157	0158	0159	0160										
R0216-03	18	26	31	6	9	76			0161	0162	0163	0164	0165	0166	0167										
R0216-03	18	26	31	6	9	86			0168	0169	0170	0171	0172	0173	0174										
R0216-03	18	26	31	6	9	96			0675	0676	0677	0681	0682	0683	0684										
R0216-03	18	26	31	6	9	116				0175	0176	0177													
R0216-03	18	26	31	6	9	136				0178	0179	0180													
R0216-03	20	26	31	6	9	17		0181	0182	0183	0184	0185													
R0216-03	20	26	31	6	9	22		0186	0187	0188	0189	0190	0191												
R0216-03	20	26	31	6	9	27		0192	0193	0194	0195	0196	0197	0198	0199			0200							
R0216-03	20	26	31	6	9	36		0201	0202	0203	0204	0205	0206	0207	0208			0209							
R0216-03	20	26	31	6	9	46		0210	0211	0212	0213	0214	0215	0216	0217			0218							
R0216-03	20	26	31	6	9	56		0219	0220	0221	0222	0223	0224	0225	0226										
R0216-03	20	26	31	6	9	66		0227	0228	0229	0230	0231	0232	0233	0234										
R0216-03	20	26	31	6	9	76			0235	0236	0237	0238	0239	0240	0241										
R0216-03	20	26	31	6	9	86			0242	0243	0244	0245	0246	0247	0248										
R0216-03	20	26	31	6	9	96			0678	0679	0680	0685	0686	0687	0688										
R0216-03	20	26	31	6	9	116				0249	0250	0251													
R0216-03	20	26	31	6	9	136				0252	0253	0254													
R0216-03	22	30	35	6	9	22		0255	0256	0257	0258	0259	0260												
R0216-03	22	30	35	6	9	27		0261	0262	0263	0264	0265		0266	0267			0268		0269					
R0216-03	22	30	35	6	9	36		0270	0271	0272	0273	0274		0275	0276			0277		0278					

R0216 Colonna guida due diametri spallata con forzatura - R00 Two diameters guide pillar with centering collar for a tight fit - R00

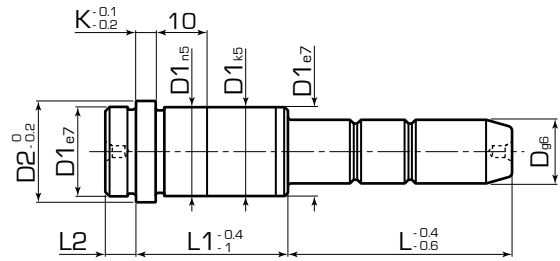

by **RANCO**

Descrizione:

Materiale: 1.7131 ≈60 HRC
Rivestimento: DLC su richiesta
Esempio di ordinativo: R0216-03-0001

Description:

Material: 1.7131 ≈60 HRC
Coating: DLC upon request
Example of purchasing order: R0216-03-0001

Codice Code	D	D1	D2	K	L2	L1	L																
							25	35	55	75	95	115	135	155	195	215	235	245	275				
R0216-03	22	30	35	6	9	46		0279	0280	0281	0282	0283		0284	0285		0286						
R0216-03	22	30	35	6	9	56		0287	0288	0289	0290	0291		0292	0293								
R0216-03	22	30	35	6	9	66		0689	0294	0295	0296	0297		0298	0299								
R0216-03	22	30	35	6	9	76			0300	0301	0302	0303	0304	0305	0306								
R0216-03	22	30	35	6	9	86			0307	0308	0309	0310	0311	0312	0313		0314						
R0216-03	22	30	35	6	9	96			0690	0315	0316	0317	0318	0319	0320		0321						
R0216-03	22	30	35	6	9	116				0322	0323	0324	0325	0326	0327		0328						
R0216-03	22	30	35	6	9	136					0329	0330		0331									
R0216-03	22	30	35	6	9	156						0332		0333									
R0216-03	24	30	35	6	9	22		0334	0335	0336	0337	0338	0339										
R0216-03	24	30	35	6	9	27		0340	0341	0342	0343	0344		0345	0346		0347		0348				
R0216-03	24	30	35	6	9	36		0349	0350	0351	0352	0353		0354	0355		0356		0357				
R0216-03	24	30	35	6	9	46		0358	0359	0360	0361	0362		0363	0364		0365						
R0216-03	24	30	35	6	9	56		0366	0367	0368	0369	0370		0371	0372								
R0216-03	24	30	35	6	9	66		0691	0373	0374	0375	0376		0377	0378								
R0216-03	24	30	35	6	9	76			0379	0380	0381	0382	0383	0384	0385								
R0216-03	24	30	35	6	9	86			0386	0387	0388	0389	0390	0391	0392		0393						
R0216-03	24	30	35	6	9	96			0692	0394	0395	0396	0397	0398	0399		0400						
R0216-03	24	30	35	6	9	116				0401	0402	0403	0404	0405	0406		0407						
R0216-03	24	30	35	6	9	136					0408	0409		0410									
R0216-03	24	30	35	6	9	156						0411		0412									
R0216-03	30	42	47	6	9	27			0413	0414	0415	0416		0417	0418		0419		0420				
R0216-03	30	42	47	6	9	36			0421	0422	0423	0424		0425	0426		0427		0428				
R0216-03	30	42	47	6	9	46			0429	0430	0431	0432		0433	0434		0435		0436				
R0216-03	30	42	47	6	9	56			0437	0438	0439	0440		0441	0442		0443		0444				
R0216-03	30	42	47	6	9	66			0445	0446	0447	0448		0449	0450		0451		0452				
R0216-03	30	42	47	6	9	76			0453	0454	0455	0456		0457	0458		0459						
R0216-03	30	42	47	6	9	86			0460	0461	0462	0463		0464	0465		0466						
R0216-03	30	42	47	6	9	96			0693	0467	0468	0469		0470	0471								
R0216-03	30	42	47	6	9	116				0472	0473	0474		0475	0476								
R0216-03	30	42	47	6	9	136					0477	0478		0479	0480								
R0216-03	30	42	47	6	9	156					0481	0482		0483									
R0216-03	30	42	47	6	9	176						0484		0485	0486								
R0216-03	30	42	47	6	9	196						0487		0488	0489								
R0216-03	32	42	47	6	9	27			0490	0491	0492	0493		0494	0495		0496		0497				
R0216-03	32	42	47	6	9	36			0498	0499	0500	0501		0502	0503		0504		0505				
R0216-03	32	42	47	6	9	46			0506	0507	0508	0509		0510	0511		0512		0513				
R0216-03	32	42	47	6	9	56			0514	0515	0516	0517		0518	0519		0520		0521				
R0216-03	32	42	47	6	9	66			0522	0523	0524	0525		0526	0527		0528		0529				
R0216-03	32	42	47	6	9	76			0530	0531	0532	0533		0534	0535		0536						
R0216-03	32	42	47	6	9	86			0537	0538	0539	0540		0541	0542		0543						
R0216-03	32	42	47	6	9	96			0694	0544	0545	0546		0547	0548								
R0216-03	32	42	47	6	9	116				0549	0550	0551		0552	0553								
R0216-03	32	42	47	6	9	136					0554	0555		0556	0557								
R0216-03	32	42	47	6	9	156					0558	0559		0560									
R0216-03	32	42	47	6	9	176						0561		0562	0563								
R0216-03	32	42	47	6	9	196						0564		0565	0566								

R0216 Colonna guida due diametri spallata con forzatura - R00 Two diameters guide pillar with centering collar for a tight fit - R00

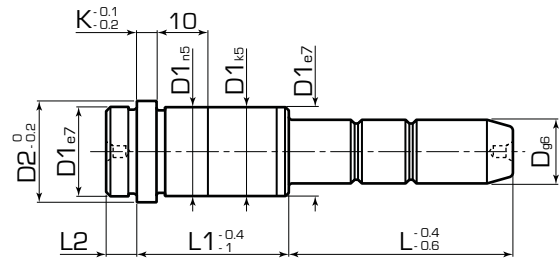

by
RANCO

Descrizione:

Materiale: 1.7131 ≈60 HRC
Rivestimento: DLC su richiesta
Esempio di ordinativo: R0216-03-0001

Description:

Material: 1.7131 ≈60 HRC
Coating: DLC upon request
Example of purchasing order: R0216-03-0001

Codice Code	D	D1	D2	K	L2	L1	L																		
							25	35	55	75	95	115	135	155	195	215	235	245	275						
R0216-03	40	54	59	10	12	36				0567	0568	0569		0570											
R0216-03	40	54	59	10	12	46				0571	0572	0573		0574											
R0216-03	40	54	59	10	12	56				0575	0576	0577		0578	0579										
R0216-03	40	54	59	10	12	66				0580	0581	0582		0583											
R0216-03	40	54	59	10	12	76				0584	0585	0586		0587											
R0216-03	40	54	59	10	12	86				0588	0589	0590		0591											
R0216-03	40	54	59	10	12	96				0592	0593	0594		0595	0596										
R0216-03	40	54	59	10	12	116				0597	0598	0599		0600	0601										
R0216-03	40	54	59	10	12	136					0602	0603		0604	0605										
R0216-03	40	54	59	10	12	156						0606		0607	0608										
R0216-03	40	54	59	10	12	176						0609		0610	0611					0612					
R0216-03	40	54	59	10	12	196						0613		0614	0615					0616					
R0216-03	40	54	59	10	12	216									0617	0618									
R0216-03	40	54	59	10	12	246										0619						0620			
R0216-03	42	54	59	10	12	36				0621	0622	0623		0624											
R0216-03	42	54	59	10	12	46				0625	0626	0627		0628											
R0216-03	42	54	59	10	12	56				0629	0630	0631		0632	0633										
R0216-03	42	54	59	10	12	66				0634	0635	0636		0637											
R0216-03	42	54	59	10	12	76				0638	0639	0640		0641											
R0216-03	42	54	59	10	12	86				0642	0643	0644		0645											
R0216-03	42	54	59	10	12	96				0646	0647	0648		0649	0650										
R0216-03	42	54	59	10	12	116				0651	0652	0653		0654	0655										
R0216-03	42	54	59	10	12	136					0656	0657		0658	0659										
R0216-03	42	54	59	10	12	156						0660		0661	0662										
R0216-03	42	54	59	10	12	176						0663		0664	0665					0666					
R0216-03	42	54	59	10	12	196						0667		0668	0669					0670					
R0216-03	42	54	59	10	12	216									0671	0672									
R0216-03	42	54	59	10	12	246										0673							0674		

R0212 Colonna guida due diametri con forzatura - R03 Two diameters guide pillar for a tight fit - R03

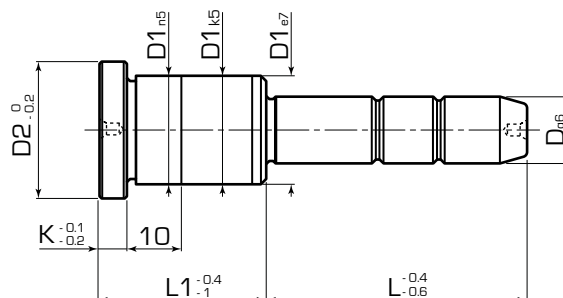

by
RANCO

Descrizione:

Materiale: 1.7131 ≈60 HRC
Rivestimento: DLC su richiesta
Esempio di ordinativo: R0212-03-0001

Description:

Material: 1.7131 ≈60 HRC
Coating: DLC upon request
Example of purchasing order: R0212-03-0001

Codice Code	D	D1	D2	K	L1	L															
						35	55	75	95	115	135	155	175	195	215	235	245				
R0212-03	14	20	25	6	17	0001	0002	0003	0004												
R0212-03	14	20	25	6	22	0005	0006	0007	0008												
R0212-03	14	20	25	6	27	0009	0010	0011	0012	0013	0014										
R0212-03	14	20	25	6	36	0015	0016	0017	0018	0019	0020										
R0212-03	14	20	25	6	46	0021	0022	0023	0024	0025	0026										
R0212-03	14	20	25	6	56		0027	0028	0029												
R0212-03	14	20	25	6	66		0030	0031	0032												
R0212-03	14	20	25	6	76		0033	0034	0035												
R0212-03	14	20	25	6	86		0036	0037	0038												
R0212-03	14	20	25	6	96		0039	0040	0041												
R0212-03	15	20	25	6	17	0042	0043	0044	0045												
R0212-03	15	20	25	6	22	0046	0047	0048	0049												
R0212-03	15	20	25	6	27	0050	0051	0052	0053	0054	0055										
R0212-03	15	20	25	6	36	0056	0057	0058	0059	0060	0061										
R0212-03	15	20	25	6	46	0062	0063	0064	0065	0066	0067										
R0212-03	15	20	25	6	56		0068	0069	0070												
R0212-03	15	20	25	6	66		0071	0072	0073												
R0212-03	15	20	25	6	76		0074	0075	0076												
R0212-03	15	20	25	6	86		0077	0078	0079												
R0212-03	15	20	25	6	96		0080	0081	0082												
R0212-03	18	26	31	6	17	0083	0084	0085	0086												
R0212-03	18	26	31	6	22	0087	0088	0089	0090												
R0212-03	18	26	31	6	27	0091	0092	0093	0094	0095		0096		0097		0098					
R0212-03	18	26	31	6	36	0099	0100	0101	0102	0103		0104		0105		0106					
R0212-03	18	26	31	6	46	0107	0108	0109	0110	0111		0112		0113							
R0212-03	18	26	31	6	56		0114	0115	0116	0117	0118										
R0212-03	18	26	31	6	66		0654	0655	0656	0657	0658	0659									
R0212-03	18	26	31	6	76		0120	0121	0122	0123	0124	0125		0662							
R0212-03	18	26	31	6	86		0126	0127	0128	0129	0130	0131		0132							
R0212-03	18	26	31	6	96		0134	0135	0136	0137											
R0212-03	18	26	31	6	116			0138	0139	0140											
R0212-03	20	26	31	6	17	0141	0142	0143	0144												
R0212-03	20	26	31	6	22	0145	0146	0147	0148												
R0212-03	20	26	31	6	27	0149	0150	0151	0152	0153		0154		0155		0156					
R0212-03	20	26	31	6	36	0157	0158	0159	0160	0161		0162		0163		0164					
R0212-03	20	26	31	6	46	0165	0166	0167	0168	0169		0170		0171							
R0212-03	20	26	31	6	56		0172	0173	0174	0175	0176										
R0212-03	20	26	31	6	66		0647	0648	0649	0650	0651	0652									
R0212-03	20	26	31	6	76		0177	0178	0179	0180	0181	0182		0653							
R0212-03	20	26	31	6	86		0183	0184	0185	0186	0187	0188		0189							
R0212-03	20	26	31	6	96		0190	0191	0192	0193											
R0212-03	20	26	31	6	116			0194	0195	0196											
R0212-03	22	30	35	6	22	0197	0198	0199	0200	0201											
R0212-03	22	30	35	6	27	0202	0203	0204	0205	0206		0207		0208							
R0212-03	22	30	35	6	36	0209	0210	0211	0212	0213		0214		0215		0216					
R0212-03	22	30	35	6	46	0217	0218	0219	0220	0221		0222		0223		0224					
R0212-03	22	30	35	6	56		0225	0226	0227	0228		0229		0230							

R0212 Colonna guida due diametri con forzatura - R03 Two diameters guide pillar for a tight fit - R03

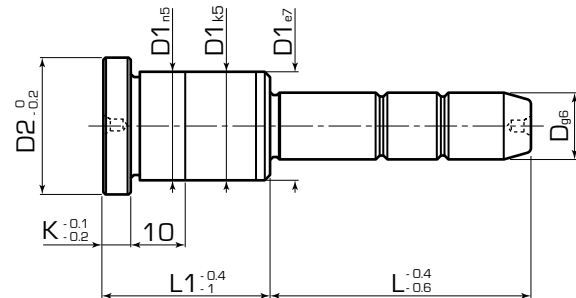

by
RANCO

Descrizione:

Materiale: 1.7131 ≈60 HRC
Rivestimento: DLC su richiesta
Esempio di ordinativo: R0212-03-0001

Description:

Material: 1.7131 ≈60 HRC
Coating: DLC upon request
Example of purchasing order: R0212-03-0001

Codice Code	D	D1	D2	K	L1	L										
						35	55	75	95	115	135	155	175	195	215	235
R0212-03	22	30	35	6	66		0231	0232	0233	0234						
R0212-03	22	30	35	6	76		0235	0236	0237	0238	0239					
R0212-03	22	30	35	6	86		0660	0240	0241	0242	0243	0244		0245		
R0212-03	22	30	35	6	96		0663	0246	0247	0248	0249	0250		0251		
R0212-03	22	30	35	6	116			0252	0253	0254	0255	0256		0257		
R0212-03	22	30	35	6	136				0258	0259		0260				
R0212-03	22	30	35	6	156					0261		0262				
R0212-03	24	30	35	6	22	0263	0264	0265	0266	0267						
R0212-03	24	30	35	6	27	0268	0269	0270	0271	0272		0273		0274		
R0212-03	24	30	35	6	36	0275	0276	0277	0278	0279		0280		0281		0282
R0212-03	24	30	35	6	46	0283	0284	0285	0286	0287		0288		0289		0290
R0212-03	24	30	35	6	56		0291	0292	0293	0294		0295		0296		
R0212-03	24	30	35	6	66		0297	0298	0299	0300						
R0212-03	24	30	35	6	76		0301	0302	0303	0304	0305					
R0212-03	24	30	35	6	86		0661	0306	0307	0308	0309	0310		0311		
R0212-03	24	30	35	6	96		0664	0312	0313	0314	0315	0316		0317		
R0212-03	24	30	35	6	116			0318	0319	0320	0321	0322		0323		
R0212-03	24	30	35	6	136				0324	0325		0326				
R0212-03	24	30	35	6	156					0327		0328				
R0212-03	30	42	47	6	27		0329	0330	0331	0332		0333		0334		0335
R0212-03	30	42	47	6	36		0336	0337	0338	0339		0340		0341		
R0212-03	30	42	47	6	46		0342	0343	0344	0345		0346		0347		0348
R0212-03	30	42	47	6	56		0349	0350	0351	0352		0353		0354		
R0212-03	30	42	47	6	66		0355	0356	0357	0358		0359		0360		
R0212-03	30	42	47	6	76		0361	0362	0363	0364		0365		0366		
R0212-03	30	42	47	6	86			0367	0368	0369		0370		0371		
R0212-03	30	42	47	6	96		0665	0372	0373	0374		0375		0376		
R0212-03	30	42	47	6	116			0377	0378	0379		0380				
R0212-03	30	42	47	6	136				0381	0382		0383				
R0212-03	30	42	47	6	156					0384		0385				
R0212-03	30	42	47	6	196					0386		0387		0388		
R0212-03	32	42	47	6	27		0389	0390	0391	0392		0393		0394		0395
R0212-03	32	42	47	6	36		0396	0397	0398	0399		0400		0401		
R0212-03	32	42	47	6	46		0402	0403	0404	0405		0406		0407		0408
R0212-03	32	42	47	6	56		0409	0410	0411	0412		0413		0414		
R0212-03	32	42	47	6	66		0415	0416	0417	0418		0419		0420		
R0212-03	32	42	47	6	76		0421	0422	0423	0424		0425		0426		
R0212-03	32	42	47	6	86			0427	0428	0429		0430		0431		
R0212-03	32	42	47	6	96		0666	0432	0433	0434		0435		0436		
R0212-03	32	42	47	6	116			0437	0438	0439		0440				
R0212-03	32	42	47	6	136				0441	0442		0443				
R0212-03	32	42	47	6	156					0444		0445				
R0212-03	32	42	47	6	196					0446		0447		0448		
R0212-03	40	54	59	10	36			0449	0450	0451		0452				
R0212-03	40	54	59	10	46			0453	0454	0455		0456				
R0212-03	40	54	59	10	56			0457	0458	0459		0460				
R0212-03	40	54	59	10	66			0461	0462	0463		0464				

R0212 Colonna guida due diametri con forzatura - R03 Two diameters guide pillar for a tight fit - R03

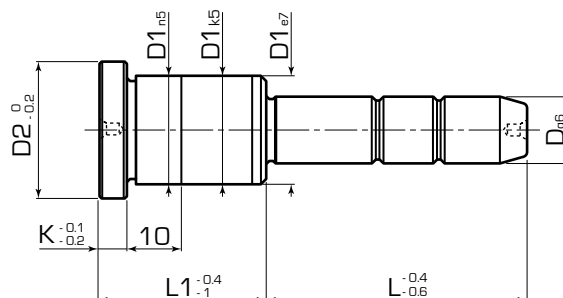

by
RANCO

Descrizione:

Materiale: 1.7131 ≈60 HRC
Rivestimento: DLC su richiesta
Esempio di ordinativo: R0212-03-0001

Description:

Material: 1.7131 ≈60 HRC
Coating: DLC upon request
Example of purchasing order: R0212-03-0001

Codice Code	D	D1	D2	K	L1	L											
						35	55	75	95	115	135	155	175	195	215	235	245
R0212-03	40	54	59	10	76			0465	0466	0467		0468					
R0212-03	40	54	59	10	86			0469	0470	0471		0472					
R0212-03	40	54	59	10	96			0473	0474	0475		0476					
R0212-03	40	54	59	10	116			0477	0478	0479		0480					
R0212-03	40	54	59	10	136				0481	0482		0483		0484			
R0212-03	40	54	59	10	156					0485		0486		0487			
R0212-03	40	54	59	10	176					0488		0489		0490			
R0212-03	40	54	59	10	196					0491		0492		0493			
R0212-03	40	54	59	10	216									0494	0495		
R0212-03	40	54	59	10	246										0496		0497
R0212-03	42	54	59	10	36			0498	0499	0500		0501					
R0212-03	42	54	59	10	46			0502	0503	0504		0505					
R0212-03	42	54	59	10	56			0506	0507	0508		0509					
R0212-03	42	54	59	10	66			0510	0511	0512		0513					
R0212-03	42	54	59	10	76			0514	0515	0516		0517					
R0212-03	42	54	59	10	86			0518	0519	0520		0521					
R0212-03	42	54	59	10	96			0522	0523	0524		0525					
R0212-03	42	54	59	10	116			0526	0527	0528		0529					
R0212-03	42	54	59	10	136				0530	0531		0532		0533			
R0212-03	42	54	59	10	156					0534		0535		0536			
R0212-03	42	54	59	10	176					0537		0538		0539			
R0212-03	42	54	59	10	196					0540		0541		0542			
R0212-03	42	54	59	10	216									0543	0544		
R0212-03	42	54	59	10	246										0545		0546
R0212-03	50	66	71	10	76			0547	0548	0549	0550	0551	0552	0553			
R0212-03	50	66	71	10	96				0554	0555	0556	0557	0558	0559	0560		
R0212-03	50	66	71	10	116					0561	0562	0563	0564	0565	0566		
R0212-03	50	66	71	10	136					0567	0568	0569	0570	0571	0572		
R0212-03	50	66	71	10	156						0573	0574	0575	0576	0577		
R0212-03	50	66	71	10	176							0578	0579	0580	0581		0613
R0212-03	50	66	71	10	196							0619	0620	0621	0622		0623
R0212-03	50	66	71	10	216							0629	0630	0631	0632		0633
R0212-03	50	66	71	10	246								0639	0640	0641		0642
R0212-03	52	66	71	10	76			0582	0583	0584	0585	0586	0587	0588			
R0212-03	52	66	71	10	96				0589	0590	0591	0592	0593	0594	0595		
R0212-03	52	66	71	10	116					0596	0597	0598	0599	0600	0601		
R0212-03	52	66	71	10	136					0602	0603	0604	0605	0606	0607		
R0212-03	52	66	71	10	156						0608	0609	0610	0611	0612		
R0212-03	52	66	71	10	176							0614	0615	0616	0617		0618
R0212-03	52	66	71	10	196								0624	0625	0626	0627	0628
R0212-03	52	66	71	10	216								0634	0635	0636	0637	0638
R0212-03	52	66	71	10	246									0643	0644	0645	0646

R0214 Bussola guida con collare spallata con foratura - R10
Shouldered guide bush with centering collar for a tight fit - R10

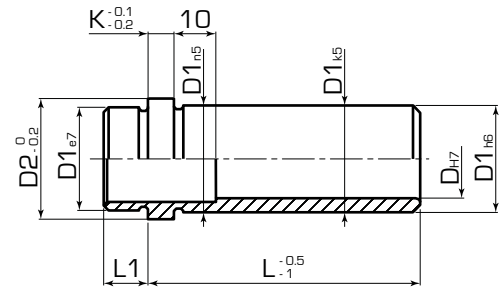

by
RANCO

Descrizione:

Material: 1.7131 ≈60 HRC
Esempio di ordinativo: R0214-03-0001

Description:

Material: 1.7131 ≈60 HRC
Example of purchasing order: R0214-03-0001

Codice Code	D	D1	D2	K	L1	L													
						17	22	27	36	46	56	66	76	86	96	116	136	156	196
R0214-03	14	20	25	6	9	0001	0002	0003	0004	0005	0006	0007	0008	0009	0010				
R0214-03	15	20	25	6	9	0011	0012	0013	0014	0015	0016	0017	0018	0019	0020				
R0214-03	18	26	31	6	9	0021	0022	0023	0024	0025	0026	0027	0028	0029	0030	0031			
R0214-03	20	26	31	6	9	0032	0033	0034	0035	0036	0037	0038	0039	0040	0041	0042			
R0214-03	22	30	35	6	9		0043	0044	0045	0046	0047	0048	0049	0050	0051	0052	0053		
R0214-03	24	30	35	6	9		0054	0055	0056	0057	0058	0059	0060	0061	0062	0063	0064		
R0214-03	30	42	47	6	9			0065	0066	0067	0068	0069	0070	0071	0072	0073	0074	0075	
R0214-03	32	42	47	6	9			0076	0077	0078	0079	0080	0081	0082	0083	0084	0085	0086	
R0214-03	40	54	59	10	12				0087	0088	0089	0090	0091	0092	0093	0094	0095	0096	0097
R0214-03	42	54	59	10	12				0098	0099	0100	0101	0102	0103	0104	0105	0106	0107	0108

R0215 Bussola guida con collare con forzatura - R11
 Guide bush with collar for a tight fit - R11

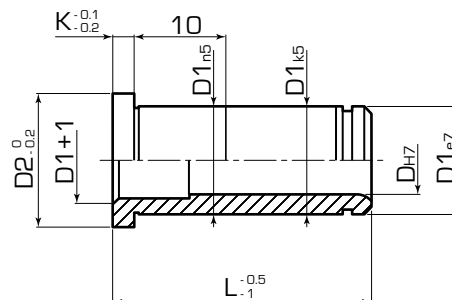

by **RANCO**

Descrizione:

Materiale: 1.7131 ≈60 HRC
 Esempio di ordinativo: R0215-03-0001

Description:

Material: 1.7131 ≈60 HRC
 Example of purchasing order: R0215-03-0001

Codice Code	D	D1	D2	K	L														
					17	22	27	36	46	56	66	76	86	96	116	136	156	196	246
R0215-03	14	20	25	6	0001	0002	0003	0004	0005	0006	0007	0008	0009	0010					
R0215-03	15	20	25	6	0011	0012	0013	0014	0015	0016	0017	0018	0019	0020					
R0215-03	16	22	26	6	0021	0022	0023	0024	0025	0026	0027	0028	0029	0030					
R0215-03	18	26	31	6	0031	0032	0033	0034	0035	0036	0037	0038	0039	0040	0041				
R0215-03	20	26	31	6	0042	0043	0044	0045	0046	0047	0048	0049	0050	0051	0052				
R0215-03	22	30	35	6		0053	0054	0055	0056	0057	0058	0059	0060	0061	0062	0063			
R0215-03	24	30	35	6		0064	0065	0066	0067	0068	0069	0070	0071	0072	0073	0074			
R0215-03	30	42	47	6			0075	0076	0077	0078	0079	0080	0081	0082	0083	0084	0085		
R0215-03	32	42	47	6			0086	0087	0088	0089	0090	0091	0092	0093	0094	0095	0096		
R0215-03	40	54	59	10				0097	0098	0099	0100	0101	0102	0103	0104	0105	0106	0107	
R0215-03	42	54	59	10				0108	0109	0110	0111	0112	0113	0114	0115	0116	0117	0118	
R0215-03	50	66	71	10								0119		0121	0122	0123	0124		0125
R0215-03	52	66	71	10								0126		0128	0129	0130	0131		0132

R0213 Bussola centraggio - R20
Centering bush - R20

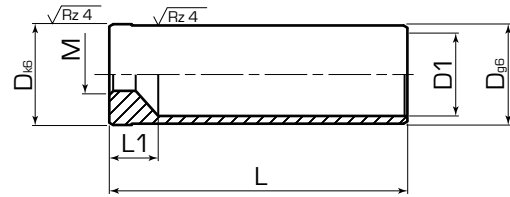

by
RANCO

Descrizione:

Material: 1.7131 ≈60 HRC
Esempio di ordinativo: R0213-03-0001

Description:

Material: 1.7131 ≈60 HRC
Example of purchasing order: R0213-03-0001

Codice Code	D	D1	M	L1	L																		
					20	30	40	50	60	70	80	100	120	140	160	180	200	220	240	260	280	300	320
R0213-03	14	11	8	8	0001	0002	0003	0004	0005	0006	0007	0008											
R0213-03	20	16	12	12		0009	0010	0011	0012	0013	0014	0015	0016	0017	0018								
R0213-03	26	21	12	12		0019	0020	0021	0022	0023	0024	0025	0026	0027	0028	0029							
R0213-03	30	25	12	12			0030	0031	0032		0033	0034	0035	0036	0037	0038	0039	0040	0041				
R0213-03	42	33	12	12			0042		0043		0044	0045	0046	0047	0048	0049	0050	0051	0052	0053	0054	0055	
R0213-03	54	43	12	12					0056		0057	0058	0059	0060	0061		0062		0063		0064		0065
R0213-03	66	54	18	20							0066	0067	0068	0069	0070	0071	0072		0073		0074		0075
R0213-03	80	64	18	20								0076	0077	0078	0079		0080		0081		0082		0083

R0302

Bussola guida con collare in bronzo/grafite - R2087.70
 Guide bush with collar, bronze/graphite - R2087.70

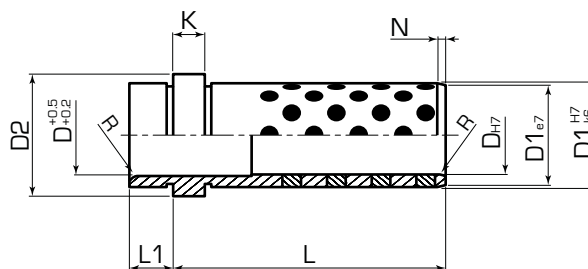

by
RANCO

Descrizione:

Materiale: Bronzo, Grafite
 Esempio di ordinativo: R0302-07-0001

Description:

Material: Bronze, Graphite
 Example of purchasing order: R0302-07-0001

Codice Code	D	D1	D2	K	N	R	L1	L																	
								12	17	22	27	36	46	56	66	76	86	96	116	136	156	196			
R0302-07	9	14	16	3	1.5	0.5	3	0001	0002	0003	0004	0005	0006	0007	0008										
R0302-07	10	14	16	3	1.5	0.5	3	0009	0010	0011	0012	0013	0014	0015	0016										
R0302-07	14	20	25	6	2	1	6		0017	0018	0019	0020	0021	0022	0023	0024	0025								
R0302-07	15	20	25	6	2	1	6		0026	0027	0028	0029	0030	0031	0032	0033	0034								
R0302-07	18	26	31	6	2	2	8		0035	0036	0037	0038	0039	0040	0041	0042	0043	0044	0045						
R0302-07	20	26	31	6	2	2	8		0046	0047	0048	0049	0050	0051	0052	0053	0054	0055	0056						
R0302-07	22	30	35	6	3	3	8		0057	0058	0059	0060	0061	0062	0063	0064	0065	0066	0067	0068	0069				
R0302-07	24	30	35	6	3	3	8		0070	0071	0072	0073	0074	0075	0076	0077	0078	0079	0080	0081	0082				
R0302-07	30	42	47	6	4	3	8				0083	0084	0085	0086	0087	0088	0089	0090	0091	0092					
R0302-07	32	42	47	6	4	3	8				0093	0094	0095	0096	0097	0098	0099	0100	0101	0102					
R0302-07	40	54	60	10	5	3	12						0103	0104	0105	0106	0107	0108	0109	0110	0111	0112			
R0302-07	42	54	60	10	5	3	12						0113	0114	0115	0116	0117	0118	0119	0120	0121	0122			

R0301 Bussola guida con collare in bronzo/grafite - R2087.72
 Guide bush with collar, bronze/graphite - R2087.72

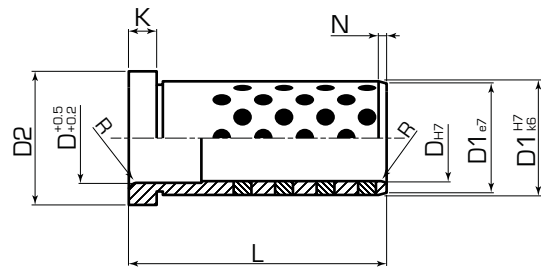

by
RANCO

Descrizione:

Materiale: Bronzo, Grafite
 Esempio di ordinativo: R0301-07-0001

Description:

Material: Bronze, Graphite
 Example of purchasing order: R0301-07-0001

Codice Code	D	D1	D2	K	N	R	L																		
							12	17	22	27	36	46	56	66	76	86	96	116	136	156	196				
R0301-07	9	14	16	3	1.5	0.5	0001	0002	0003	0004	0005	0006	0007												
R0301-07	10	14	16	3	1.5	0.5	0008	0009	0010	0011	0012	0013	0014												
R0301-07	12	18	23	6	2	1		0015	0016	0017	0018	0019	0020												
R0301-07	14	20	25	6	2	1		0021	0022	0023	0024	0025	0026												
R0301-07	15	20	25	6	2	1		0027	0028	0029	0030	0031	0032												
R0301-07	16	22	27	6	2	2		0033	0034	0035	0036	0037	0038												
R0301-07	18	26	31	6	2	2		0039	0040	0041	0042	0043	0044	0045	0046										
R0301-07	20	26	31	6	2	2		0047	0048	0049	0050	0051	0052	0053	0054										
R0301-07	22	30	35	6	3	3		0055	0056	0057	0058	0059	0060	0061	0062	0063	0064								
R0301-07	24	30	35	6	3	3		0065	0066	0067	0068	0069	0070	0071	0072	0073	0074								
R0301-07	25	32	38	6	3	3						0075	0076	0077	0078	0079									
R0301-07	30	42	47	6	4	3				0080	0081	0082	0083	0084	0085	0086	0087	0088							
R0301-07	32	42	47	6	4	3				0089	0090	0091	0092	0093	0094	0095	0096	0097							
R0301-07	40	54	60	10	5	3						0098	0099	0100	0101	0102	0103	0104	0105	0106					
R0301-07	42	54	60	10	5	3						0107	0108	0109	0110	0111	0112	0113	0114	0115					
R0301-07	50	66	72	10	5	3								0116	0117	0118	0119	0120	0121	0122	0123				
R0301-07	60	80	86	20	5	3											0124	0125	0126	0127	0128				

R0300

Bussola guida senza collare in bronzo/grafite - R2052.70
 Guide bush without collar, bronze/graphite - R2052.70

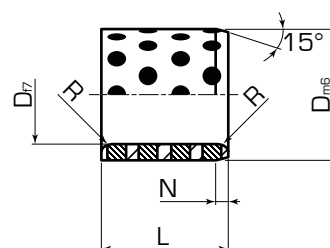

by
RANCO

Descrizione:

Materiale: Bronzo, Grafite
 Esempio di ordinativo: R0300-07-0001

Description:

Material: Bronze, Graphite
 Example of purchasing order: R0300-07-0001

Codice Code	D	D1	N	R	L																
					8	10	12	15	16	20	25	30	35	37	40	47	50	60	70	77	80
R0300-07	8	12	2	0.5	0001	0002	0003	0004													
R0300-07	10	14	2	0.5	0005	0006	0007	0008		0009											
R0300-07	10	15	2	0.5		0010															
R0300-07	12	18	2	0.5		0011	0012	0013	0014	0015	0016	0017									
R0300-07	13	19	2	0.5		0018		0019	0020	0021											
R0300-07	14	20	2	0.5		0022	0023	0024		0025	0026	0027									
R0300-07	15	21	2	0.75		0028	0029	0030	0031	0032	0033	0034									
R0300-07	16	22	2	0.75		0035	0036	0037	0038	0039	0040	0041	0042		0043						
R0300-07	18	24	2	0.75				0044	0045	0046	0047	0048	0049		0050						
R0300-07	19	25	2	0.75										0051							
R0300-07	20	26	4	0.75											0052						
R0300-07	20	28	4	0.75				0053	0054	0055	0056	0057	0058	0059	0060		0061				
R0300-07	20	30	4	0.75				0062	0063	0064	0065	0066			0067						
R0300-07	24	32	4	0.75												0068					
R0300-07	25	32	4	0.75								0269					0069				
R0300-07	25	33	4	0.75					0070	0071	0072	0073	0074		0075	0076	0077	0078			
R0300-07	25	35	4	0.75					0079	0080	0081	0082	0083		0084		0085				
R0300-07	28	38	4	0.75								0086			0087						
R0300-07	30	38	4	0.75						0088	0089	0090	0091		0092		0093	0094			
R0300-07	30	40	4	0.75						0095	0096	0097	0098		0099		0100	0101			
R0300-07	30	42	4	0.75														0102			
R0300-07	31.5	40	4	0.75								0103			0104						
R0300-07	32	42	4	0.75									0105		0106			0107			
R0300-07	35	44	4	0.75							0108	0109	0110		0111		0112	0113			
R0300-07	35	45	4	0.75						0114	0115	0116	0117		0118		0119	0120			
R0300-07	38	48	4	1.5								0121			0122					0123	
R0300-07	40	50	4	1.5						0124	0125	0126	0127		0128		0129	0130	0131	0132	0133
R0300-07	40	55	4	1.5							0134	0135	0136		0137		0138	0139			
R0300-07	45	55	4	1.5								0140	0141		0142		0143	0144			
R0300-07	45	56	4	1.5								0145	0146		0147		0148	0149			
R0300-07	45	60	4	1.5								0150	0151		0152		0153	0154	0155		0156

R0300

Bussola guida senza collare in bronzo/grafite - R2052.70
 Guide bush without collar, bronze/graphite - R2052.70

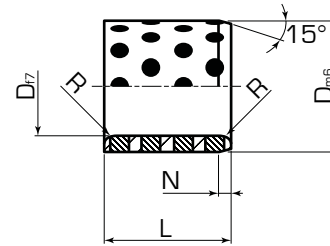

by
RANCO

Descrizione:

Materiale: Bronzo, Grafite
 Esempio di ordinativo: R0300-07-0001

Description:

Material: Bronze, Graphite
 Example of purchasing order: R0300-07-0001

Codice Code	D	D1	N	R	L															
					30	35	37	40	47	50	60	70	77	80	95	100	120	130	140	150
R0300-07	50	60	4	1.5	0157	0158		0159		0160	0161	0162		0163	0164					
R0300-07	50	62	4	1.5	0165	0166		0167		0168	0169	0170								
R0300-07	50	65	4	1.5	0171			0172		0173	0174	0175		0176		0177				
R0300-07	55	70	4	2				0178		0179	0180	0181								
R0300-07	60	74	4	2	0182	0183		0184		0185	0186	0187		0188						
R0300-07	60	75	4	2	0189	0190		0191		0192	0193	0194		0195		0196				
R0300-07	63	75	4	2							0197	0198		0199			0200			
R0300-07	65	80	4	2						0201	0202	0203		0204						
R0300-07	70	85	4	2		0205		0206		0207	0208	0209		0210		0211				
R0300-07	70	90	4	2						0212	0213	0214		0215						
R0300-07	75	90	4	2							0216	0217		0218		0219				
R0300-07	75	95	4	2							0220	0221		0222		0223				
R0300-07	80	96	4	2				0224		0225	0226	0227		0228		0229	0230			
R0300-07	80	100	4	2				0231		0232	0233	0234		0235		0236	0237		0238	
R0300-07	85	100	4	2										0239						
R0300-07	90	110	4	2							0240	0241		0242		0243	0244			
R0300-07	100	120	4	2							0245	0246		0247		0248	0249		0250	
R0300-07	110	130	4	2										0251		0252	0253			
R0300-07	120	140	4	2										0254		0255	0256		0257	
R0300-07	125	145	4	2												0258	0259			
R0300-07	130	150	4	2												0260	0261	0262		
R0300-07	140	160	4	2												0263			0264	
R0300-07	150	170	4	2												0265				0266
R0300-07	160	180	4	2												0267				0268

R0303 Bussola guida con collare spallata in bronzo/grafite - R2087.71
 Guide bush with centring collar, bronze/graphite - R2087.71

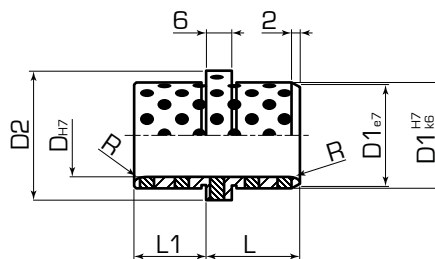

by
RANCO

Descrizione:

Materiale: Bronzo, Grafite
 Esempio di ordinativo: R0303-07-0001

Description:

Material: Bronze, Graphite
 Example of purchasing order: R0303-07-0001

Codice Code	D	D1	D2	L1	R	L			
						17	22	27	36
R0303-07	14	20	25	9	1	0001			
R0303-07	15	20	25	9	1	0002			
R0303-07	18	26	31	17	1.5		0003		
R0303-07	20	26	31	17	1.5		0004		
R0303-07	22	30	35	22	2			0005	
R0303-07	24	30	35	22	2			0006	
R0303-07	30	42	47	27	2				0007
R0303-07	32	42	47	27	2				0008

R0548

Bussola guida con collare spallata in bronzo
Bronze guide bush with centring collar

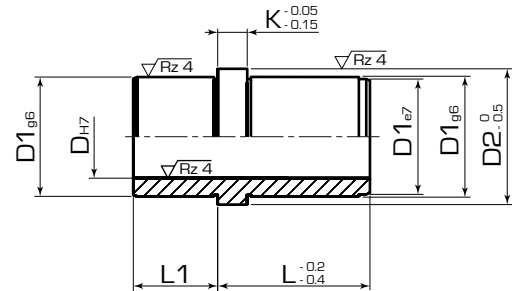

by
RANCO

Descrizione:

Materiale: Bronzo
Esempio di ordinativo: R0548-03-0001

Description:

Material: Bronze
Example of purchasing order: R0548-03-0001

Codice Code	D	D1	D2	K	L1	L					
						12	17	22	27	36	46
R0548-03	10	14	17	6	9	0001	0002				
R0548-03	12	16	19	6	9		0003				
R0548-03	12	16	19	6	12		0004				
R0548-03	14	18	21	6	12		0005	0006			
R0548-03	14	18	21	6	17			0007			
R0548-03	18	24	27	6	12		0008	0009			
R0548-03	18	24	27	6	17			0010	0011		
R0548-03	18	24	27	6	22				0012		
R0548-03	20	26	29	6	17			0013			
R0548-03	20	26	29	6	22				0014		
R0548-03	22	28	31	6	17			0015			
R0548-03	22	28	31	6	22				0016		
R0548-03	24	30	33	6	17			0017	0018		
R0548-03	24	30	33	6	22				0019		
R0548-03	24	30	33	6	27					0020	
R0548-03	30	38	41	6	22				0021		
R0548-03	30	38	41	6	27					0022	0023

R0571 Colonna distanziale filettata - R02
Threaded spacer - R02

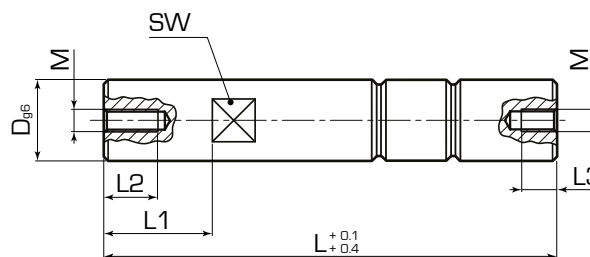

by
RANCO

Descrizione:

Materiale: 1.7131 ≈60 HRC
Esempio di ordinativo: R0571-03-0001

Description:

Material: 1.7131 ≈60 HRC
Example of purchasing order: R0571-03-0001

Codice Code	D	L1	L2	L3	M	SW	L															
							60	70	80	100	120	140	160	180	200	220	240	260	300	340	380	
R0571-03	14	14	25	17	M8	12	0001	0002	0003	0004	0005	0006	0007	0008								
R0571-03	18	16	30	20	M10	14				0009	0010	0011	0012	0013	0014	0015	0016					
R0571-03	20	18	30	20	M12	17				0017	0018	0019	0020	0021	0022	0023	0024					
R0571-03	24	22	35	25	M12	19					0025	0026	0027	0028	0029		0030					
R0571-03	30	28	45	30	M16	24								0031		0032		0033	0034			
R0571-03	40	36	55	35	M20	36							0035	0036	0037	0038	0039	0040	0041	0042	0043	

R0217 Colonna guida senza canalini - R01
Smooth guide pillar - R01

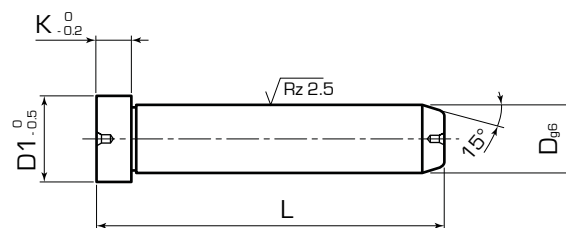

by
RANCO

Descrizione:

Materiale: 1.7131 ≈60 HRC
Rivestimento: DLC su richiesta
Esempio di ordinativo: R0217-03-0001

Description:

Material: 1.7131 ≈60 HRC
Coating: DLC upon request
Example of purchasing order: R0217-03-0001

Codice Code	D	D1	K	L																				
				40	50	60	80	100	120	140	160	180	200	220	240	260	280	300	320	340	360	400	420	500
R0217-03	8	10	3	0001	0002	0003	0004	0005																
R0217-03	9	12	3	0006		0007	0008	0009	0010															
R0217-03	10	12	3	0011		0012	0013	0014	0015	0016	0017													
R0217-03	12	16	6	0018		0019	0020	0021	0022	0023	0024	0025	0026											
R0217-03	14	18	8			0027	0028	0029	0030	0031	0032	0033	0034	0035	0036									
R0217-03	15	18	8			0037	0038	0039	0040	0041	0042	0043	0044	0045	0046									
R0217-03	16	20	8	0047		0048	0049	0050	0051	0052	0053	0054	0055	0056	0057				0058					
R0217-03	18	22	8			0059	0060	0061	0062	0063	0064	0065	0066	0067	0068	0069	0070	0071	0072					
R0217-03	20	24	8			0073	0074	0075	0076	0077	0078	0079	0080	0081	0082	0083	0084	0085	0086					
R0217-03	22	26	15				0087	0088	0089	0090	0091	0092	0093	0094	0095	0096	0097	0098	0099	0100	0101			
R0217-03	24	28	15				0102	0103	0104	0105	0106	0107	0108	0109	0110	0111	0112	0113	0114	0115	0116			
R0217-03	30	36	15					0117	0118	0119	0120	0121	0122	0123	0124			0125			0126	0127		
R0217-03	32	36	15					0128	0129	0130	0131	0132	0133		0134			0135			0136	0137		
R0217-03	40	48	15								0138	0139	0140		0141			0142			0143	0144		
R0217-03	50	58	15								0146	0147	0148		0149			0150			0151	0152		
R0217-03	60	68	20												0153	0154	0155		0158	0159	0156	0157		

R0218 Colonna guida due diametri con forzatura - R011
Two diameters guide pillar for a tight fit - R011

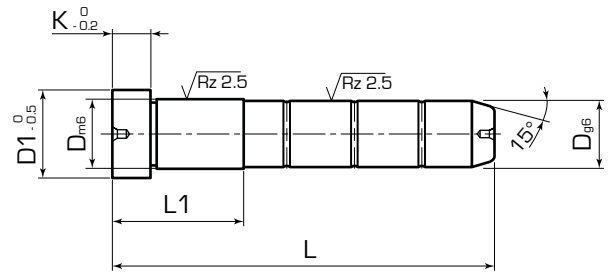

by
RANCO

Descrizione:

Materiale: 1.7131 ≈60 HRC
Rivestimento: DLC su richiesta
Esempio di ordinativo: R0218-03-0001

Description:

Material: 1.7131 ≈60 HRC
Coating: DLC upon request
Example of purchasing order: R0218-03-0001

Codice Code	D	D1	K	L																									
				40	60	80	100	120	140	160	180	180	180	200	200	200	220	240	240	280	300	320	360	360	400	500			
				L1																									
				17	17	22	27	27	36	36	36	46	56	36	46	56	56	46	56	56	56	56	76	76	96				
R0218-03	10	12	3	0001	0002	0003	0004																						
	12	16	6		0005	0006	0007	0008																					
	14	18	8		0009	0010	0011	0012	0013	0014	0015																		
	16	20	8		0016	0017	0018	0019	0020	0021	0022			0023					0024										
	18	22	8			0025	0026	0027	0028	0029		0030					0031			0032	0033								
	20	24	8			0034	0035	0036	0037	0038			0039			0040			0041	0042									
	22	26	15				0043	0044	0045	0046		0047				0048	0049		0050	0051	0052	0053	0054						
	24	28	15				0055	0056	0057	0058		0059				0060	0061		0062	0063	0064	0065	0066						
	30	36	15							0067						0068			0069	0070	0071		0072						
	32	36	15							0073						0074			0075	0076	0077		0078						
	40	48	15													0079			0080		0081				0082	0083			
	50	58	15													0084			0085		0086			0087	0088	0089			
	60	68	20																0090		0091			0092	0093	0094			

R0537 Colonna guida con forzata
Guide pillar for a tight fit

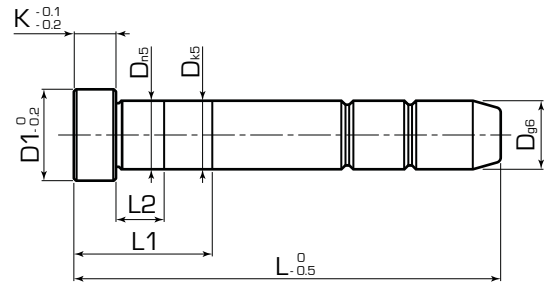

by
RANCO

Descrizione:

Materiale: 1.7131 ≈60 HRC
Rivestimento: DLC su richiesta
Esempio di ordinativo: R0537-03-0001

Description:

Material: 1.7131 ≈60 HRC
Coating: DLC upon request
Example of purchasing order: R0537-03-0001

Codice Code	D	D1	K	L1	L2	L																		
						60	80	100	120	140	160	180	200	220	250	280	320	360	400	450	500			
R0537-03	14	17	6	22	6	0001	0002	0003	0004															
R0537-03	14	17	6	27	10					0005	0006													
R0537-03	15	18	6	22	6	0007	0008	0009	0010															
R0537-03	15	18	6	27	10					0011	0012													
R0537-03	16	19	6	22	6		0013	0014	0015															
R0537-03	16	19	6	27	10					0016	0017													
R0537-03	18	21	6	22	6		0018	0019	0020															
R0537-03	18	21	6	27	10					0021	0022	0023												
R0537-03	18	21	6	36	10								0024	0025										
R0537-03	20	23	6	22	6		0026	0027	0028															
R0537-03	20	23	6	27	10					0029	0030	0031												
R0537-03	20	23	6	36	10								0032	0033										
R0537-03	22	25	6	27	10			0034	0035	0036	0037	0038												
R0537-03	22	25	6	36	10								0039	0040	0041									
R0537-03	22	25	6	46	10											0042								
R0537-03	24	27	6	27	10			0043	0044	0045	0046	0047												
R0537-03	24	27	6	36	10								0048	0049	0050									
R0537-03	24	27	6	46	10											0051								
R0537-03	30	35	6	36	10			0052	0053	0054	0055	0056	0057	0058										
R0537-03	30	35	6	46	10											0059	0060							
R0537-03	30	35	6	56	10													0061						
R0537-03	32	37	6	36	10			0062	0063	0064	0065	0066	0067	0068										
R0537-03	32	37	6	46	10											0069	0070							
R0537-03	32	37	6	56	10													0071						
R0537-03	40	45	10	46	15				0072			0073		0074	0075									
R0537-03	40	45	10	56	15											0076	0077							
R0537-03	40	45	10	66	15													0078	0079					
R0537-03	42	47	10	46	15				0080			0081		0082	0083									
R0537-03	42	47	10	46	15											0084	0085							
R0537-03	42	47	10	66	15													0086	0087					
R0537-03	50	55	10	56	15							0088		0089	0090	0091								
R0537-03	50	55	10	66	15												0092	0093						
R0537-03	50	55	10	76	15														0094	0095				
R0537-03	52	57	10	56	15							0096		0097	0098	0099								
R0537-03	52	57	10	66	15												0100	0101						
R0537-03	52	57	10	76	15														0102	0103				

R0529 Colonna guida senza canalini con forzatura
Smooth guide pillar for a tight fit

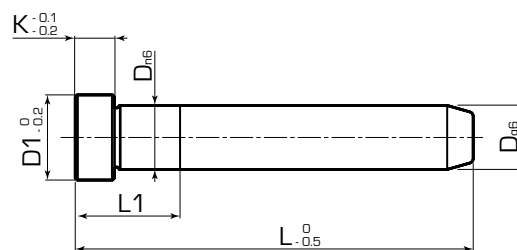

by
RANCO

Descrizione:

Materiale: 1.7131 ≈60 HRC
Rivestimento: DLC su richiesta
Esempio di ordinativo: R0529-03-0001

Description:

Material: 1.7131 ≈60 HRC
Coating: DLC upon request
Example of purchasing order: R0529-03-0001

Codice Code	D	D1	K	L1	L															
					60	80	100	120	140	160	180	200	220	240	250	280	320	360	400	
R0529-03	14	17	8	22	0001	0002	0003	0004	0005	0006	0007									
R0529-03	16	19	8	22	0008	0009	0010	0011	0012	0013	0014	0015								
R0529-03	18	21	8	22	0016	0017	0018	0019	0020	0021	0022	0023	0024	0025						
R0529-03	20	23	8	22		0026	0027	0028	0029	0030	0031	0032	0033	0034						
R0529-03	22	25	10	27		0035	0036	0037	0038	0039	0040	0041	0042	0043		0044				
R0529-03	24	27	10	27		0045	0046	0047	0048	0049	0050	0051	0052	0053		0054				
R0529-03	30	35	10	36			0055	0056	0057	0058	0059	0060	0061	0062		0063	0064	0065		
R0529-03	32	35	10	36			0066	0067	0068	0069	0070	0071	0072	0073		0074	0075	0076		
R0529-03	40	45	10	36					0077	0078	0079	0080			0081	0082	0083	0084	0085	

R0211 Colonna inclinata senza testa
Inclined pin without collar

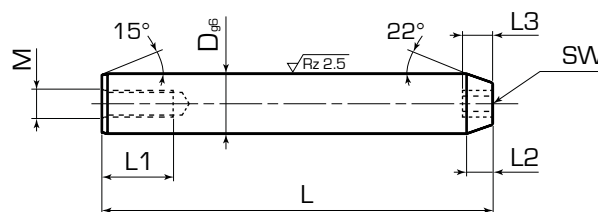

by
RANCO

Descrizione:

Materiale: 1.7131 ≈60 HRC
Rivestimento: DLC su richiesta
Esempio di ordinativo: R0211-03-0001

Description:

Material: 1.7131 ≈60 HRC
Coating: DLC upon request
Example of purchasing order: R0211-03-0001

Codice Code	D	M	L1	SW	L2	L3	L																														
							40	50	60	70	75	80	90	100	110	120	125	130	140	145	150	160	165	170	180	190	200	210	220	240	260						
R0211-03	8	5	10	4	2.3	4	0105	0106		0107	0108																										
R0211-03	10	6	10	4	4	4	0109	0001	0110	0002	0003	0004																									
R0211-03	12	6	10	5	5	5	0111	0005		0006	0007	0008			0009		0010																				
R0211-03	14	6	10	5	5	5	0011	0012	0013	0014	0015	0016	0017		0018		0019		0020			0112															
R0211-03	15	8	17	5	5	5	0021	0022	0023		0024	0025																									
R0211-03	16	8	17	6	5	6		0026			0027	0028	0029	0113	0030		0031	0032			0033		0034		0035		0114										
R0211-03	18	8	17	6	7	6		0036	0037		0038	0039	0040	0115	0041	0042		0043		0044	0045		0046	0047		0048		0049									
R0211-03	20	10	20	8	7	8		0050	0051		0052	0053	0054	0116	0055	0056		0057		0058	0059	0117	0060	0061	0062	0063	0064	0065	0066	0118							
R0211-03	22	10	20	8	7	8		0067	0068		0069	0070	0071		0072		0073		0074		0075		0076		0077	0078											
R0211-03	24	12	25	8	7	8		0079	0080		0081	0082	0083		0084		0085	0086		0087		0088	0119	0089		0090	0091										
R0211-03	30	16	30	10	7	10					0092	0093	0094		0095		0096					0120															
R0211-03	32	16	30	10	7	10					0097	0098	0099		0100		0101																				

R0690 Gruppo guida (bussola - gabbia a sfere) con collare spallata - R12M
Shouldered guiding unit (bush - ball cage) with centering collar - R12M

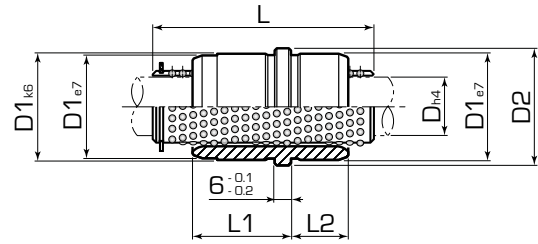

by
RANCO

Descrizione:

Materiale:
Bussola: 1.7131 ≈60 HRC
Gabbia: Ottone
Sfera: Acciaio INOX

Description:

Material:
Bush: 1.7131 ≈60 HRC
Cage: Brass
Ball: Stainless Steel

Codice Code	D	L	D1	D2	L1	L2	Corsa max. max. Stroke
R0690-03-0001	12	40	22	25	17	9	35
R0690-03-0002	12	56	22	25	17	9	80
R0690-03-0003	18	45	30	33	22	12	45
R0690-03-0004	18	56	30	33	22	12	65
R0690-03-0005	18	71	30	33	22	12	90
R0690-03-0006	24	56	38	41	27	17	45
R0690-03-0007	24	71	38	41	27	17	75
R0690-03-0008	24	80	38	41	27	17	105
R0690-03-0009	30	71	46	49	32	22	55
R0690-03-0010	30	95	46	49	32	22	95
R0690-03-0011	30	105	46	49	32	22	135

R0691 Bussola guida con collare spallata per gabbia a sfere - R12MB3
Shouldered guide bush with centering collar for ball cage - R12MB3

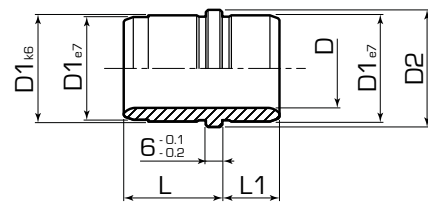

by
RANCO

Descrizione:

Materiale: 1.7131 ≈60 HRC

Description:

Material: 1.7131 ≈60 HRC

Codice Code	D	D1	D2	L	L1
R0691-03-0001	16	22	25	17	9
R0691-03-0002	24	30	33	22	12
R0691-03-0003	30	38	41	27	17
R0691-03-0004	38	46	49	32	22

R0692 Colonna guida senza canalini per scorrimento sfere con forzatura - R012M
 Smooth guide pillar with collar for ball bearing sliding - R012M

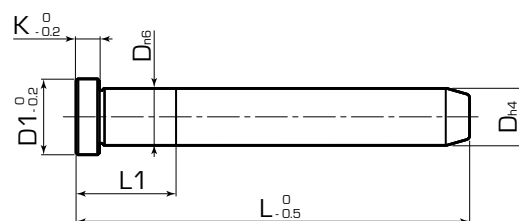

by
RANCO

Descrizione:

Materiale: 1.7131 ≈60 HRC
 Esempio di ordinativo: R0692-03-0001

Description:

Material: 1.7131 ≈60 HRC
 Example of purchasing order: R0692-03-0001

Codice Code	D	D1	L1	K	L						
					80	100	120	140	160	200	250
R0692-03	12	15	17	4	0001	0002	0003				
R0692-03	18	21	22	6			0004	0005	0006		
R0692-03	24	27	27	6				0007	0008	0009	
R0692-03	30	35	36	6					0010	0011	0012

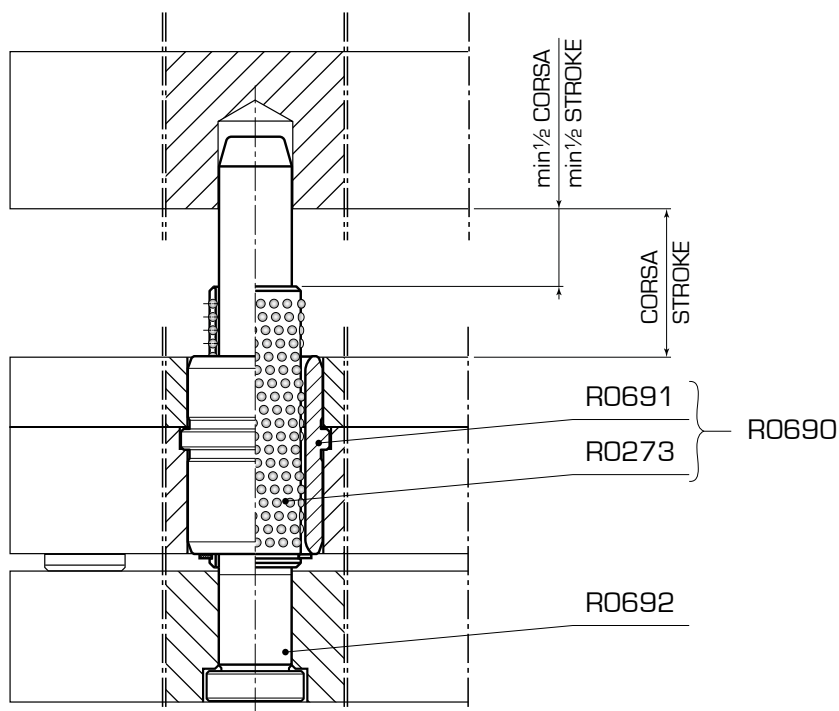

R0693 Colonna guida senza testa - senza canalini per scorrimento sfere - R013M
 Smooth guide pillar without collar for ball bearing sliding - R013M

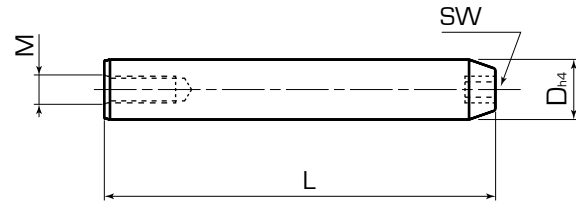

by
RANCO

Descrizione:

Material: 1.7131 ≈60 HRC
 Esempio di ordinativo: R0693-03-0001

Description:

Material: 1.7131 ≈60 HRC
 Example of purchasing order: R0693-03-0001

Codice Code	D	M	SW	L					
				100	120	140	160	200	250
R0693-03	12	M8	5	0001	0002				
R0693-03	18	M10	6		0003	0004	0005		
R0693-03	24	M12	8			0006	0007	0008	
R0693-03	30	M16	8				0009	0010	0011

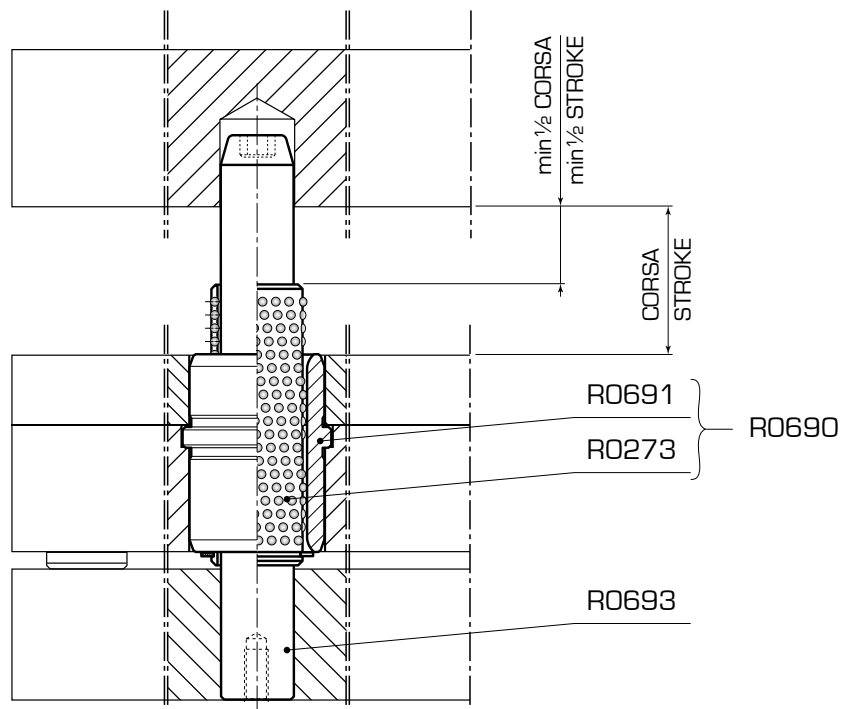

R0273 Gabbia a sfere - GS
Ball cage - GS

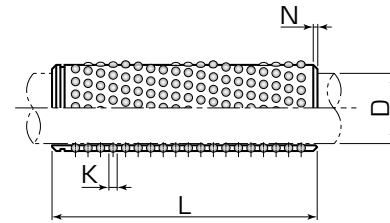

by
RANCO

Descrizione:

Materiale:
Gabbia: Ottone
Sfera: Acciaio INOX
Esempio di ordinativo: R0273-04-0001

Description:

Material:
Cage: Brass
Ball: Stainless Steel
Example of purchasing order: R0273-04-0001

Codice Code	D	K	N	L												
				31	40	45	50	56	71	75	80	95	105	120	140	160
R0273-04	12	2	2.2		0006			0007								
R0273-04	18	3	2.9			0143		0144	0145							
R0273-04	24	3	2.9	0032	0033	0034		0035	0036		0037	0038	0147	0039		
R0273-04	30	4	3.95		0048	0049	0050	0051	0052	0146	0053	0054	0055	0056	0057	0058

R0574 Bussola guida con collare spallata a ricircolo sfere - BRSSM Shouldered recirculating ball guide bush with centering collar - BRSSM

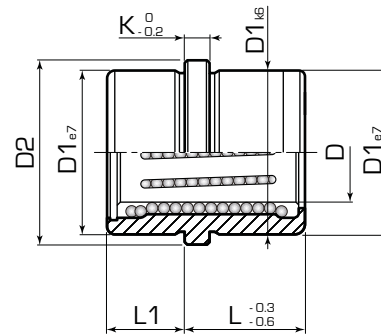

by
RANCO

Descrizione:

Material: 1.7131 ≈60 HRC
Bussola: 1.7131 ≈60 HRC
Gabbia: Ottone
Sfera: Acciaio INOX
Esempio di ordinativo: R0574-03-0001

Description:

Material: 1.7131 ≈60 HRC
Bush: 1.7131 ≈60 HRC
Cage: Brass
Ball: Stainless Steel
Example of purchasing order: R0574-03-0001

Codice Code	D	D1	D2	L1	K	L				
						17	22	27	32	36
R0574-03	12	22	25	9	6	0001				
R0574-03	12	22	25	12	6	0002				
R0574-03	18	30	33	12	6		0003			
R0574-03	18	30	33	17	6		0004			
R0574-03	24	38	41	17	6			0005		
R0574-03	24	38	41	22	6			0006		
R0574-03	30	46	49	22	6				0007	
R0574-03	30	46	49	27	6					0008

R0220 Bussola guida con collare a ricircolo sfere - BRSC Recirculating ball guide bush with collar - BRSC

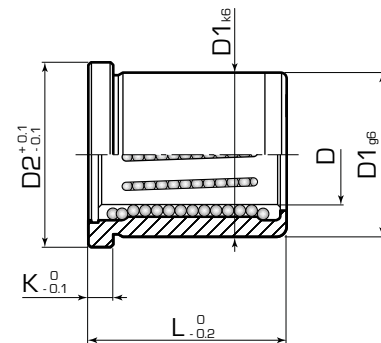

by
RANCO

Descrizione:

Material: 1.7131 ≈60 HRC
Bussola: 1.7131 ≈60 HRC
Gabbia: Ottone
Sfera: Acciaio INOX
Esempio di ordinativo: R0220-03-0001

Description:

Material: 1.7131 ≈60 HRC
Bush: 1.7131 ≈60 HRC
Cage: Brass
Ball: Stainless Steel
Example of purchasing order: R0220-03-0001

Codice Code	D	D1	D2	K	Diam. Sfere Diam. Ball	Numero linee Line number	L			
							35	45	55	63
R0220-03	20	32	36	6	3	6	0001			
R0220-03	25	40	45	6	3	8	0002	0003	0004	
R0220-03	32	50	56	8	4	8		0005		0006
R0220-03	40	60	66	8	4	8		0007		0008

R0221

Bussola guida senza collare a ricircolo sfere - BRSL
Recirculating ball guide bush without collar - BRSL

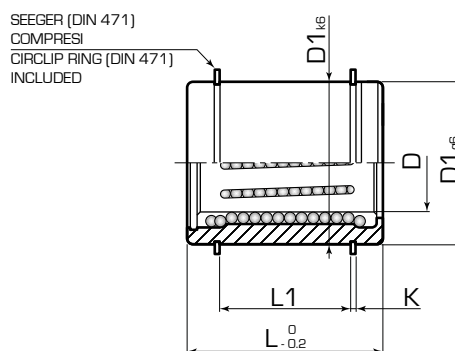

by
RANCO

Descrizione:

Materiale:
Bussola: 1.7131 ≈60 HRC
Gabbia: Ottone
Sfera: Acciaio INOX
Esempio di ordinativo: R0221-03-0001

Description:

Material:
Bush: 1.7131 ≈60 HRC
Cage: Brass
Ball: Stainless Steel
Example of purchasing order: R0221-03-0001

Codice Code	D	D1	L1	K	Diam. Sfere Diam. Ball	Numero linee Line number	L					
							30	35	45	55	63	
R0221-03	12	24	20	1.3	3	5	0001					
R0221-03	16	28	19	1.6	3	6	0002					
R0221-03	16	28	24	1.6	3	6		0003				
R0221-03	20	32	24	1.6	3	6		0004				
R0221-03	20	32	34	1.6	3	6			0005			
R0221-03	25	40	23	1.8	3	8		0006				
R0221-03	25	40	33	1.8	3	8			0007			
R0221-03	25	40	43	1.8	3	8				0008		
R0221-03	32	50	33	2.1	4	8			0009			
R0221-03	32	50	51	2.1	4	8						0010
R0221-03	40	60	33	2.1	4	8			0011			
R0221-03	40	60	51	2.1	4	8						0012

R0222 Bussola guida con collare spallata a ricircolo sfere - BRSS
Shouldered recirculating ball guide bush with centering collar - BRSS

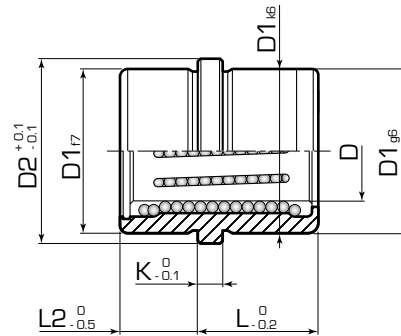

by
RANCO

Descrizione:

Material:
Bussola: 1.7131 ~60 HRC
Gabbia: Ottone
Sfera: Acciaio INOX
Esempio di ordinativo: R0222-03-0001

Description:

Material:
Bush: 1.7131 ~60 HRC
Cage: Brass
Ball: Stainless Steel
Example of purchasing order: R0222-03-0001

Codice Code	D	D1	D2	L1	K	Diam. Sfere Diam. Ball	Numero linee Line number	L						
								22	26	35	45	55	63	
R0222-03	12	24	28	8	6	3	5	0001						
R0222-03	16	28	32	8	6	3	6	0002						
R0222-03	16	28	32	9	6	3	6		0003					
R0222-03	20	32	36	9	6	3	6		0004	0005				
R0222-03	25	40	45	9	6	3	8		0006					
R0222-03	25	40	45	10	6	3	8			0007	0008	0009		
R0222-03	32	50	56	12	8	4	8				0010			0011
R0222-03	40	60	66	12	8	4	8				0012			0013

R0528 Colonna guida senza canalini per scorrimento sfere - R012
Smooth guide pillar for ball bearing sliding - R012

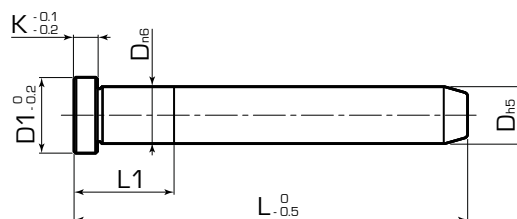

by
RANCO

Descrizione:

Materiale: 1.7131 ≈60 HRC
Esempio di ordinativo: R0528-03-0001

Description:

Material: 1.7131 ≈60 HRC
Example of purchasing order: R0528-03-0001

Codice Code	D	D1	L1	K	L								
					80	100	125	160	200	250	315	400	
R0528-03	12	16	16	4	0001	0002	0003						
R0528-03	16	20	20	6	0004	0005	0006	0007	0008				
R0528-03	20	24	22	6		0009	0010	0011	0012	0013			
R0528-03	25	30	25	6			0014	0015	0016	0017	0018		
R0528-03	32	37	35	8			0019		0020	0021	0022		
R0528-03	40	45	35	8			0023		0024	0025	0026	0027	
R0528-03	50	55	45	10							0028	0029	
R0528-03	60	65	55	10							0030	0031	

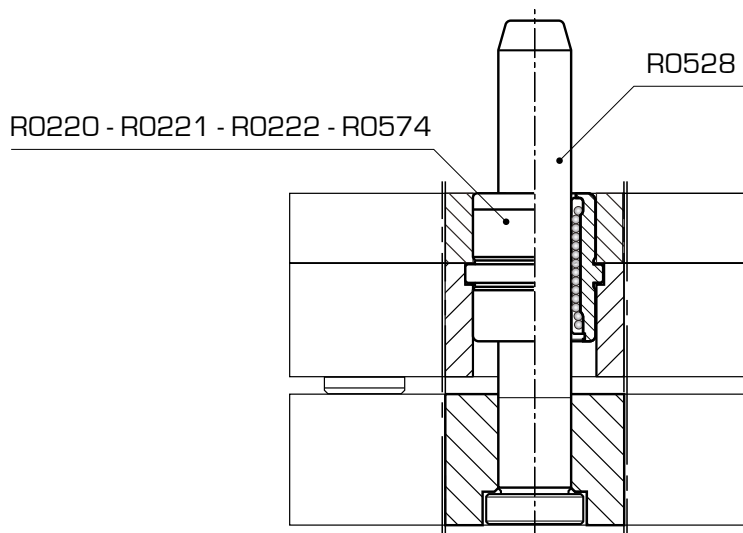

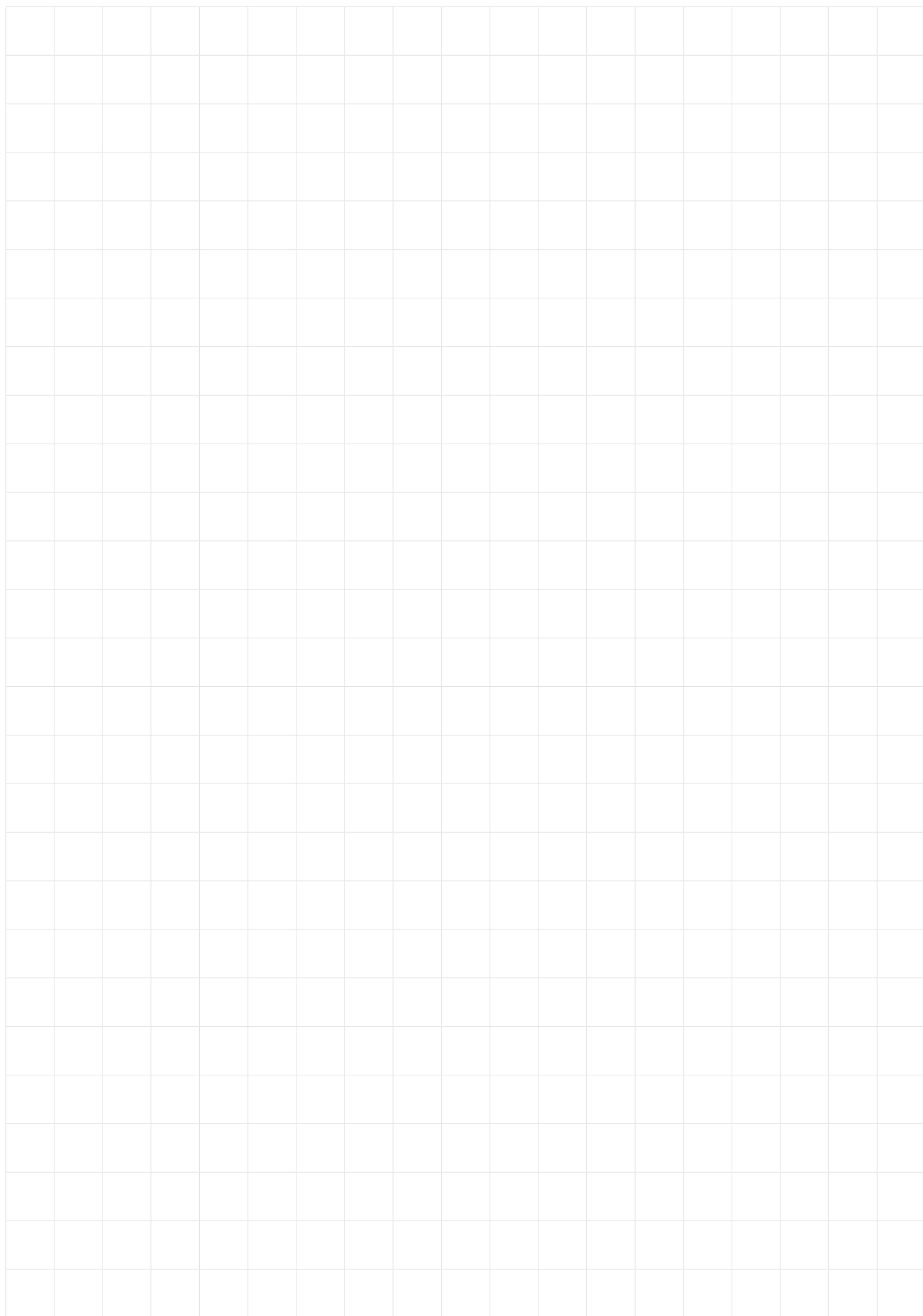

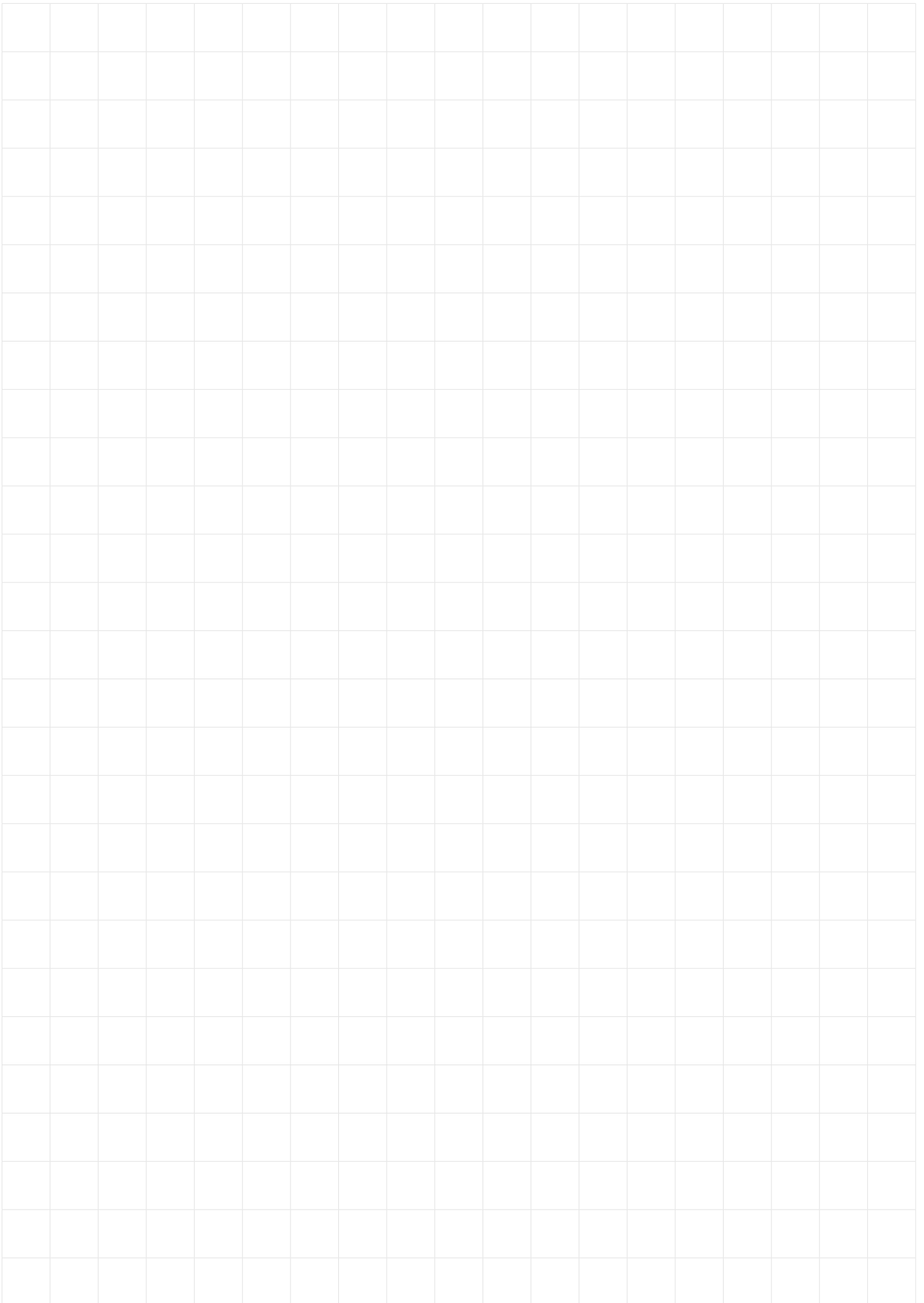

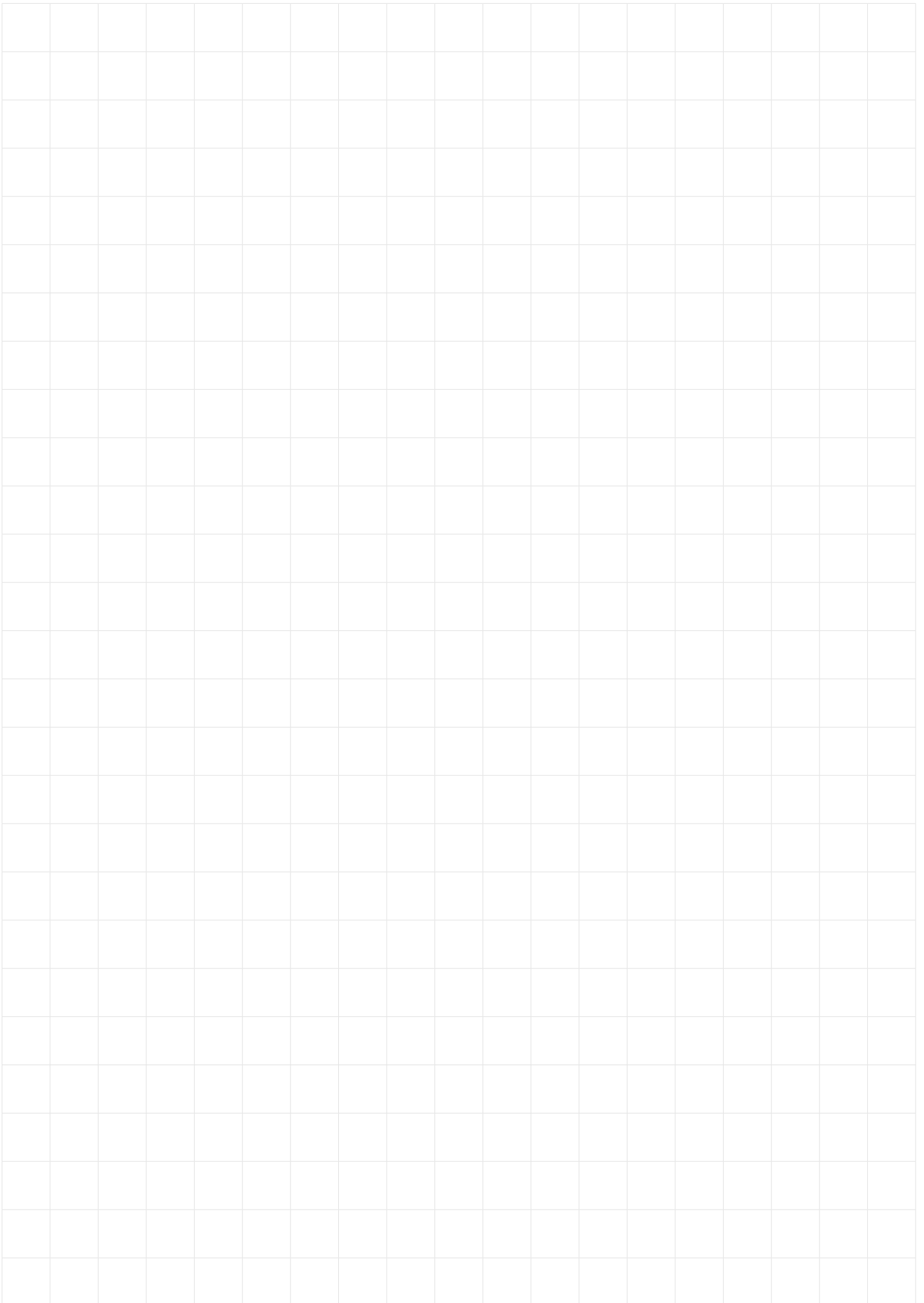

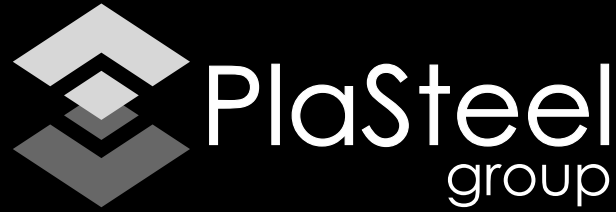

www.plasteelgroup.com

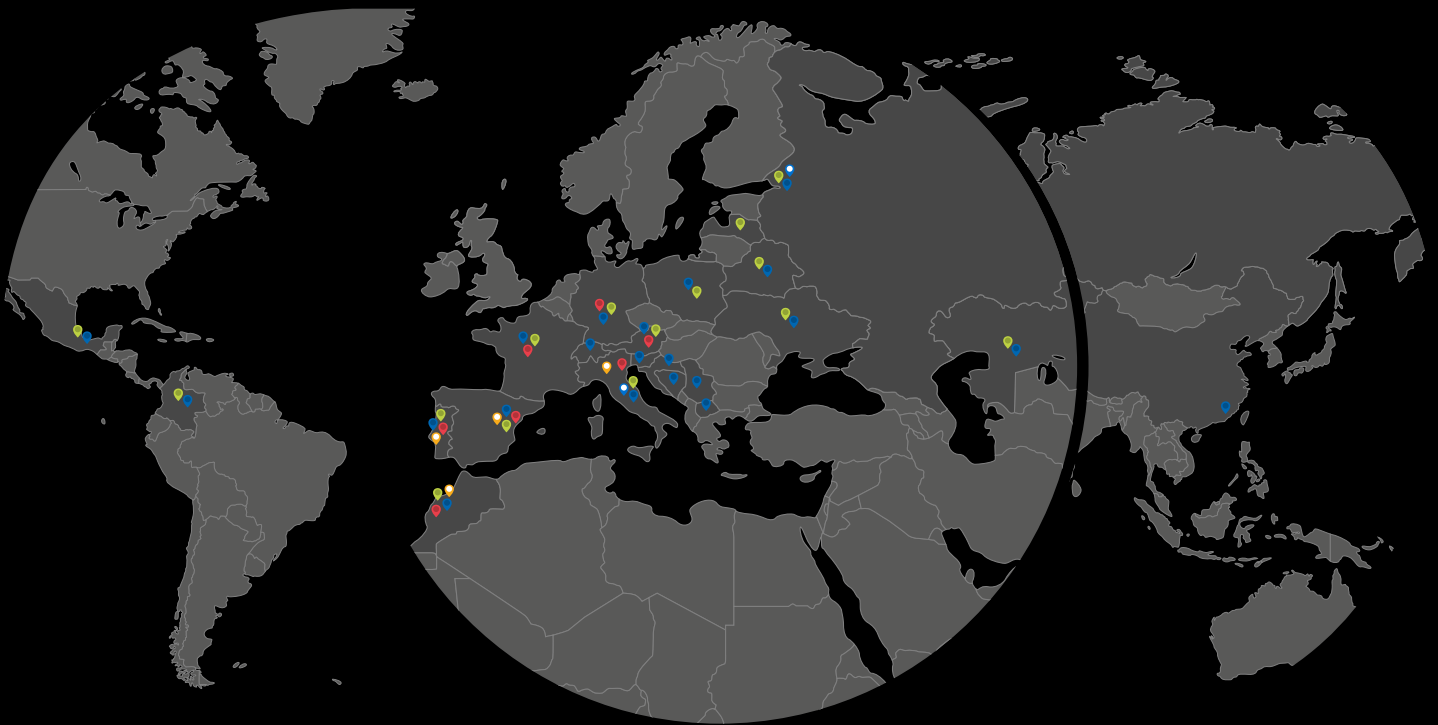

Ranco Srl
www.ranco.biz



iHR Srl
www.ihrsolution.it



Tecnostar Group Srl
www.tecnostargroup.it



Technology & Solutions Srl
www.tecsolutions.it



Promec Fittings Srl
www.promecfittings.com

TecnostarGroup S.r.l.

Via Dante, 2/A - 35020 Sant'Angelo di Piove di Sacco (Pd) - Italia

Tel: +39 049 9705728 - Fax: +39 049 971 1523

www.tecnostargroup.it - info@tecnostargroup.it

